

Assist Rails

Assembly, Installation and Operating Instructions

Model No. 6632



Yes, you can.

SAVE THESE INSTRUCTIONS

NOTE: The 6632 Assist Rails are ONLY to be used with the following Invacare Beds: 5410LOW, 5410IVC, 5410, 5310IVC, 5310, 5307IVC, 5307 and VC5310.

NOTE: Check all parts for shipping damage before using. In case of damage, DO NOT use the equipment. Contact the dealer/carrier for further instructions.

To ensure the safe and proper installation of the Assist Rails, these instructions **MUST** be followed:

⚠ WARNINGS

DO NOT install or use this equipment without first reading and understanding these instructions. If you are unable to understand the Warnings, Cautions or Instructions, contact a healthcare professional, dealer or technical personnel before attempting to install this equipment - otherwise, death, injury or property damage may occur.

These assist rails are intended to prevent an individual from inadvertently rolling out of bed. **DO NOT** use for restraint purposes.

ENTRAPMENT MAY OCCUR. Proper patient assessment and monitoring, and proper maintenance and use of equipment is required to reduce the risk of entrapment. Variations in bed rail dimensions, and mattress thickness, size or density could increase the risk of entrapment. Visit the FDA website at <http://www.fda.gov> to learn about the risks of entrapment. Review **A Guide to Bed Safety**, published by the Hospital Bed Safety Workgroup, located at www.invacare.com. Use the link located under each bed rail product entry to access this bed safety guide.

Invacare products are specifically designed and manufactured for use in conjunction with Invacare accessories. Accessories designed by other manufacturers have not been tested by Invacare and are not recommended for use with Invacare products.

Although assist rails are not rated to any specific weight limitation, the assist rails may become deformed or broken if excessive side pressure is exerted on the side rails. The assist rails when used in the UP position, are designed to aid the user in sitting up or entering/exiting the bed. The assist rails should not be used to support the full weight of the user. **DO NOT** use the assist rails as push handles when moving the bed.

After any adjustments, repair or service and before use, make sure all attaching hardware is tightened securely. Assist rails with dimensions different from the original equipment supplied or specified by the bed manufacturer may not be interchangeable and may result in entrapment or other injury.

Ensure adjustment pins are fully engaged before using the guard or assist positions.

For more information regarding Invacare products, parts, and services, please visit www.invacare.com

⚠ WARNINGS

NEVER install two assist rails on the same side of the bed.

Assist rail is not designed to be used with any additional rail mounted to the bed.

Install assist rails only in the pre-punched mounting holes in the bed frame. When mounted correctly the minimum distance between the assist rail in the assist (up) position and the head board will be approximately 17 inches.

Mattress **MUST** fit bed frame and assist rails snugly to reduce the risk of entrapment.

Installation

NOTE: For this procedure, refer to FIGURE 1 on page 3.

NOTE: Tools required: 1/2 inch deep socket or use extension

NOTE: Assist rails are shipped in pairs, one right and one left.

NOTE: Right and left are determined by the user's position as if in the bed.

1. Elevate the head section to allow access to the bed frame.
2. On the left side of bed, align the two top threaded bushings of the assist rail with the bed frame mounting holes.
3. Secure the assist rail to the bed frame using two mounting bolts and locking washers,

⚠ WARNING

DO NOT use assist rails without crossbar installed. Otherwise, injury may result.

CAUTION

Install the crossbar as shown in FIGURE 1. Otherwise, the crossbar will interfere with the pull tube of the motor possibly resulting in damage to the unit.

4. Align the crossbar with the lower threaded bushing of the left assist rail (FIGURE 1).
5. Secure the crossbar to the left assist rail using one mounting bolt and locking washers.
6. Repeat STEPS 1 and 2 for the right assist rail on the right side of the bed.
7. Align the crossbar with the lower threaded bushing of the right assist rail (FIGURE 1).
8. Secure the crossbar to the right assist rail using two mounting bolts and locking washers.

NOTE: Ensure that the tube is positioned above the mounting holes before tightening.

9. Torque the bolts from STEPS 2 and 7 to 14 to 16 inch-pounds.

WARNING
 Patient entrapment with bed side rails may cause injury or death. Mattress must fit bed frame and side rails snugly to prevent patient entrapment. Follow the manufacturer's instructions. Monitor patient frequently. Read and understand the Owner's/Operator's Manual prior to using this equipment. Manual is available at www.invacare.com or your dealer.

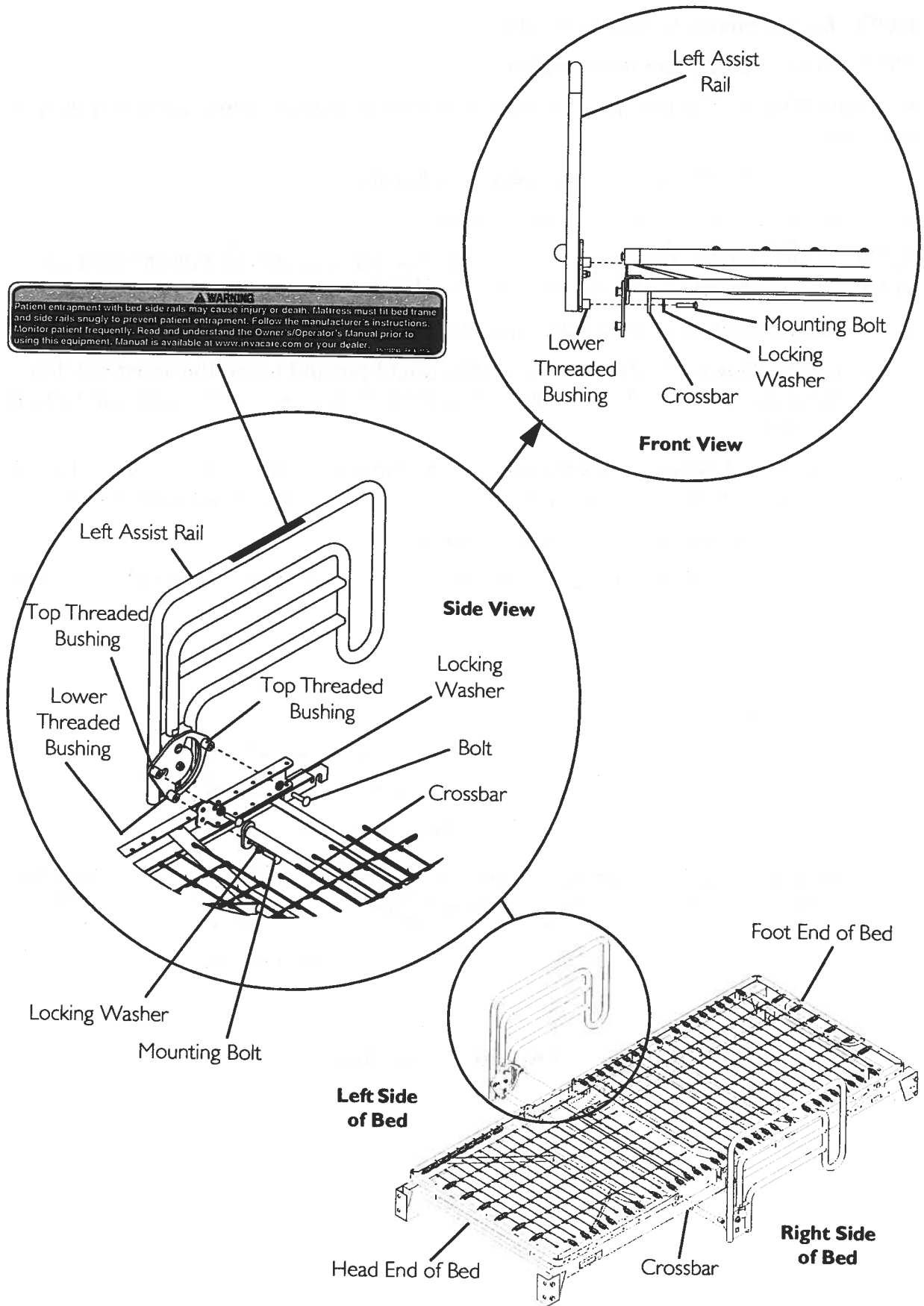

FIGURE I Installation

LIMITED WARRANTY

PLEASE NOTE: THE WARRANTY BELOW HAS BEEN DRAFTED TO COMPLY WITH FEDERAL LAW APPLICABLE TO PRODUCTS MANUFACTURED AFTER JULY 4, 1975.

This warranty is extended only to the original purchaser/user of our products.

This warranty gives you specific legal rights and you may also have other legal rights which vary from state to state.

Invacare warrants its product to be free from defects in materials and workmanship for two years for the original purchaser. If within such warranty period any such product shall be proven to be defective, such product shall be repaired or replaced, at Invacare's option. This warranty does not include any labor or shipping charges incurred in replacement part installation or repair of any such product. Invacare's sole obligation and your exclusive remedy under this warranty shall be limited to such repair and/or replacement.

For warranty service, please contact the dealer from whom you purchased your Invacare product. In the event you do not receive satisfactory warranty service, please write directly to Invacare at the address below. Provide dealer's name, address, model number, date of purchase, indicate nature of the defect and, if the product is serialized, indicate the serial number.

Invacare Corporation will issue a return authorization. The defective unit or parts must be returned for warranty inspection using the serial number, when applicable, as identification within thirty days of return authorization date. DO NOT return products to our factory without our prior consent. C.O.D. shipments will be refused; please prepay shipping charges.

LIMITATIONS AND EXCLUSIONS: THE WARRANTY SHALL NOT APPLY TO PROBLEMS ARISING FROM NORMAL WEAR OR FAILURE TO ADHERE TO THE ENCLOSED INSTRUCTIONS. IN ADDITION, THE FOREGOING WARRANTY SHALL NOT APPLY TO SERIAL NUMBERED PRODUCTS IF THE SERIAL NUMBER HAS BEEN REMOVED OR DEFACED; PRODUCTS SUBJECTED TO NEGLIGENCE, ACCIDENT, IMPROPER OPERATION, MAINTENANCE OR STORAGE; OR PRODUCTS MODIFIED WITHOUT INVACARE'S EXPRESS WRITTEN CONSENT INCLUDING, BUT NOT LIMITED TO: MODIFICATION THROUGH THE USE OF UNAUTHORIZED PARTS OR ATTACHMENTS; PRODUCTS DAMAGED BY REASON OF REPAIRS MADE TO ANY COMPONENT WITHOUT THE SPECIFIC CONSENT OF INVACARE; PRODUCTS DAMAGED BY CIRCUMSTANCES BEYOND INVACARE'S CONTROL; PRODUCTS REPAIRED BY ANYONE OTHER THAN AN INVACARE DEALER, SUCH EVALUATION SHALL BE SOLELY DETERMINED BY INVACARE.

THE FOREGOING EXPRESS WARRANTY IS EXCLUSIVE AND IN LIEU OF ANY OTHER WARRANTIES WHATSOEVER, WHETHER EXPRESS OR IMPLIED, INCLUDING THE IMPLIED WARRANTIES OF MERCHANTABILITY AND FITNESS FOR A PARTICULAR PURPOSE, AND THE SOLE REMEDY FOR VIOLATIONS OF ANY WARRANTY WHATSOEVER, SHALL BE LIMITED TO REPAIR OR REPLACEMENT OF THE DEFECTIVE PRODUCT PURSUANT TO THE TERMS CONTAINED HEREIN. THE APPLICATION OF ANY IMPLIED WARRANTY WHATSOEVER SHALL NOT EXTEND BEYOND THE DURATION OF THE EXPRESS WARRANTY PROVIDED HEREIN. THE MANUFACTURER SHALL NOT BE LIABLE FOR ANY CONSEQUENTIAL OR INCIDENTAL DAMAGES WHATSOEVER.

THIS WARRANTY SHALL BE EXTENDED TO COMPLY WITH STATE/PROVINCIAL LAWS AND REQUIREMENTS.

Reduced Gap Half-Length Bed Rail

Assembly, Installation and Operating Instructions



Model Nos. 6630

Yes, you can.

SAVE THESE INSTRUCTIONS

NOTE: Check all parts for shipping damage before using. In case of damage, DO NOT use the equipment. Contact the dealer/carrier for further instructions.

To ensure the safe use of the Reduced Gap Half Length Bed Rail, these instructions **MUST** be followed:

⚠ WARNINGS

DO NOT install or use this equipment without first reading and understanding these instructions. If you are unable to understand the **Warnings, Cautions or Instructions**, contact a healthcare professional, dealer or technical personnel before attempting to install this equipment - otherwise, death, injury or property damage may occur.

Invacare recommends the use of two sets of half length bed rails: one set at the head end of the bed, and one set at the foot end of the bed where permitted.

These bed rails are intended to prevent an individual from inadvertently rolling out of bed. **DO NOT** use for restraint purposes.

ENTRAPMENT MAY OCCUR. Proper patient assessment and monitoring, and proper maintenance and use of equipment is required to reduce the risk of entrapment. Variations in bed rail dimensions, and mattress thickness, size or density could increase the risk of entrapment. Visit the FDA website at <http://www.fda.gov> to learn about the risks of entrapment. Review **A Guide to Bed Safety**, published by the Hospital Bed Safety Workgroup, located at www.invacare.com. Use the link located under each bed rail product entry to access this bed safety guide.

Invacare products are specifically designed and manufactured for use in conjunction with Invacare accessories. Accessories designed by other manufacturers have not been tested by Invacare and are not recommended for use with Invacare products.

Although bed rails are not rated to any specific weight limitation, the bed rails may become deformed or broken if excessive side pressure is exerted on the bed rails. This bed rail is not an assist rail for getting into or out of bed. **DO NOT** use the bed rails as push handles when moving the bed.

After any adjustments, repair or service and before use, make sure all attaching hardware is tightened securely. Bed rails with dimensions different from the original equipment supplied or specified by the bed manufacturer may not be interchangeable and may result in entrapment or other injury.

To reduce the risk of entrapment make certain that the crossbraces **DO NOT** exceed the width of the mattress. Mattress **MUST** fit bed frame and bed rails snugly to reduce the risk of entrapment.

For more information regarding Invacare products, parts, and services,
please visit www.invacare.com

⚠ WARNINGS (CONTINUED)

Unless the bed rail is in the lowest position, ensure that the spring loaded pins fully protrude through the same respective adjustment hole of each bed rail tube. This ensures that the bed rail is securely locked in position and an even height adjustment is achieved. (The lowest position for the bed rail occurs when the bed rail rests against the bed rail stop. Spring loaded pins DO NOT engage into an adjustment hole when the bed rail in the lowest position.)

Installing the Crossbraces

READ AND UNDERSTAND WARNINGS before proceeding with procedure.

NOTE: For this procedure, refer to FIGURE 1 on page 3.

Tools required are 13 mm socket wrench.

1. Remove the mattress from the bed.
2. Place the bed in the flat position.
3. Bolt the crossbraces to the half rails (Detail "A" in FIGURE 1).
4. Position the crossbraces in the following manner (Detail "B" in FIGURE 1):
 - A. Head End - The crossbrace should be approximately 11 inches (28 cm) from the inside edge of the bed frame.
 - B. Foot End - The crossbrace should be approximately 11 inches (28 cm) from the inside edge of the bed frame.

NOTE: Avoid the bed springs when installing the bed rails. If the 11-inch dimension, stated above, falls in alignment with a bed spring then the bed rail needs to be mounted on either side of the bed spring.

5. Loosen the wingnut under the crossbrace.
6. Slide the long side of the clamp under the bed frame, making sure the bent portion of the clamp is positioned towards the inside of the bed (Detail "C" in FIGURE 1).
7. Tighten the wingnut to secure the clamp to the bed frame.
8. Repeat STEPS 3-7 for the remaining three wingnuts and clamps.

Using the Bed Rails

NOTE: For this procedure, refer to FIGURE 1 on page 3 .

1. Ensure the bed rails are flush against the bed frame.
2. While holding bed rail with one hand, pull spring-loaded knob with other hand to lower bed rail (Detail "B" in FIGURE 1).
3. Pull bed rail up to lock into position.
4. Periodically check and retighten mounting hardware.

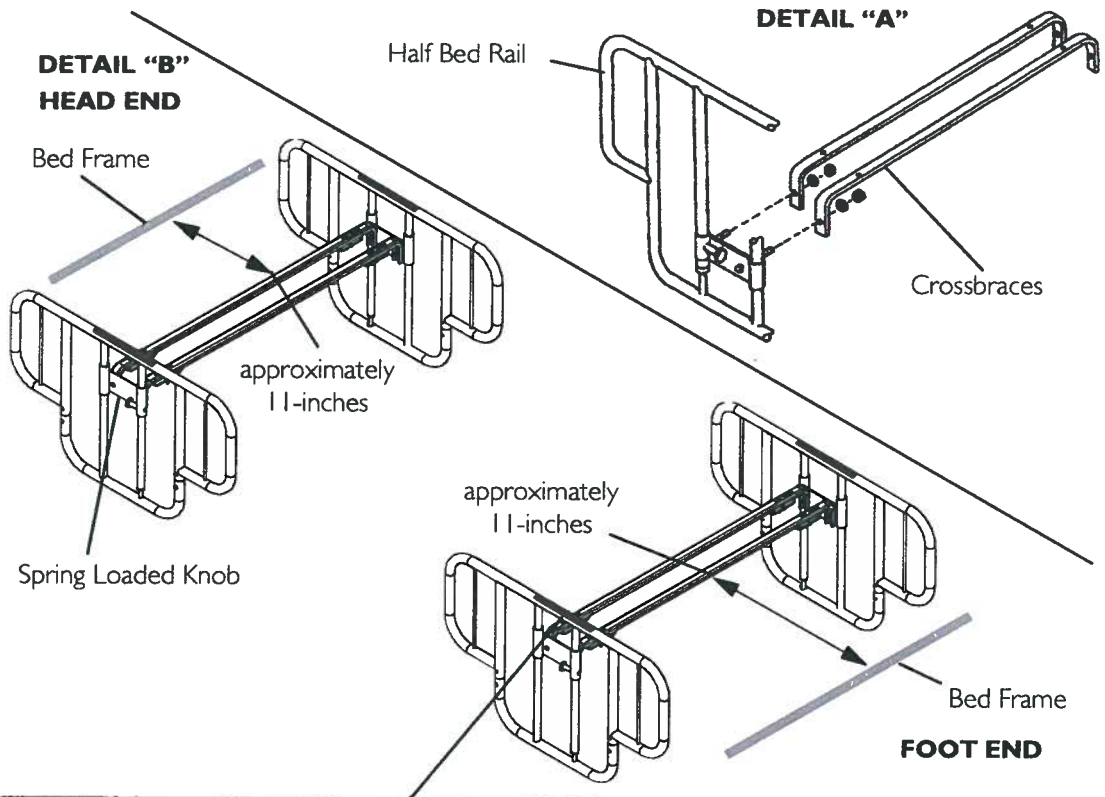

WARNING
 Patient entrapment with bed side rails may cause injury or death. Mattress must fit bed frame and side rails snugly to prevent patient entrapment. Follow the manufacturer's Instructions. Monitor patient frequently. Read and understand the Owner's/Operator's Manual prior to using this equipment. Manual is available at www.invacare.com or your dealer.

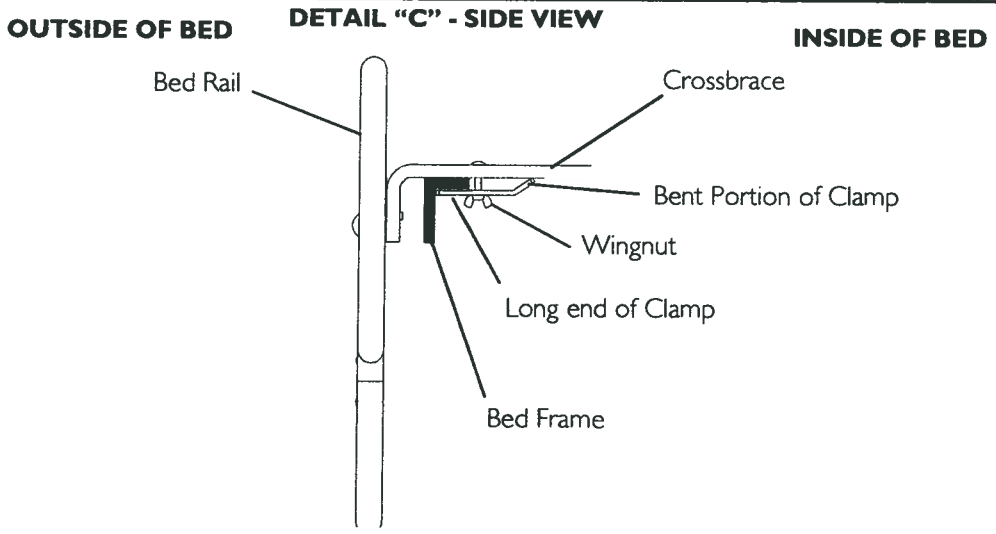

FIGURE 1 Installing the Crossbraces/Using the Bed Rails

LIMITED WARRANTY

PLEASE NOTE: THE WARRANTY BELOW HAS BEEN DRAFTED TO COMPLY WITH FEDERAL LAW APPLICABLE TO PRODUCTS MANUFACTURED AFTER JULY 4, 1975.

This warranty is extended only to the original purchaser/user of our products.

This warranty gives you specific legal rights and you may also have other legal rights which vary from state to state.

Invacare warrants its product to be free from defects in materials and workmanship for two years for the original purchaser. If within such warranty period any such product shall be proven to be defective, such product shall be repaired or replaced, at Invacare's option. This warranty does not include any labor or shipping charges incurred in replacement part installation or repair of any such product. Invacare's sole obligation and your exclusive remedy under this warranty shall be limited to such repair and/or replacement.

For warranty service, please contact the dealer from whom you purchased your Invacare product. In the event you do not receive satisfactory warranty service, please write directly to Invacare at the address on the back page. Provide dealer's name, address, model number, and the date of purchase, indicate nature of the defect and, if the product is serialized, indicate the serial number.

Invacare Corporation will issue a return authorization. The defective unit or parts must be returned for warranty inspection using the serial number, when applicable, as identification within thirty (30) days of return authorization date. DO NOT return products to our factory without our prior consent. C.O.D. shipments will be refused; please prepay shipping charges.

LIMITATIONS AND EXCLUSIONS: THE WARRANTY SHALL NOT APPLY TO PROBLEMS ARISING FROM NORMAL WEAR OR FAILURE TO ADHERE TO THE ENCLOSED INSTRUCTIONS. IN ADDITION, THE FOREGOING WARRANTY SHALL NOT APPLY TO SERIAL NUMBERED PRODUCTS IF THE SERIAL NUMBER HAS BEEN REMOVED OR DEFACED; PRODUCTS SUBJECTED TO NEGLIGENCE, ACCIDENT, IMPROPER OPERATION, MAINTENANCE OR STORAGE; OR PRODUCTS MODIFIED WITHOUT INVACARE'S EXPRESS WRITTEN CONSENT INCLUDING, BUT NOT LIMITED TO: MODIFICATION THROUGH THE USE OF UNAUTHORIZED PARTS OR ATTACHMENTS; PRODUCTS DAMAGED BY REASON OF REPAIRS MADE TO ANY COMPONENT WITHOUT THE SPECIFIC CONSENT OF INVACARE; PRODUCTS DAMAGED BY CIRCUMSTANCES BEYOND INVACARE'S CONTROL; PRODUCTS REPAIRED BY ANYONE OTHER THAN AN INVACARE DEALER, SUCH EVALUATION SHALL BE SOLELY DETERMINED BY INVACARE.

THE FOREGOING EXPRESS WARRANTY IS EXCLUSIVE AND IN LIEU OF ALL OTHER EXPRESS WARRANTIES WHATSOEVER, WHETHER EXPRESS OR IMPLIED, INCLUDING THE IMPLIED WARRANTIES OF MERCHANTABILITY AND FITNESS FOR A PARTICULAR PURPOSE AND THE SOLE REMEDY FOR VIOLATIONS OF ANY WARRANTY WHATSOEVER, SHALL BE LIMITED TO REPAIR OR REPLACEMENT OF THE DEFECTIVE PRODUCT PURSUANT TO THE TERMS CONTAINED HEREIN. THE APPLICATION OF ANY IMPLIED WARRANTY WHATSOEVER SHALL NOT EXTEND BEYOND THE DURATION OF THE EXPRESS WARRANTY PROVIDED HEREIN. INVACARE SHALL NOT BE LIABLE FOR ANY CONSEQUENTIAL OR INCIDENTAL DAMAGES WHATSOEVER.

THIS WARRANTY SHALL BE EXTENDED TO COMPLY WITH STATE/PROVINCIAL LAWS AND REQUIREMENTS.

Which Ways of Reducing Risks are Best?

A process that requires ongoing patient evaluation and monitoring will result in optimizing bed safety. Many patients go through a period of adjustment to become comfortable with new options. Patients and their families should talk to their health care planning team to find out which options are best for them.

Patient or Family Concerns About Bed Rail Use

If patients or family ask about using bed rails, health care providers should:

- Encourage patients or family to talk to their health care planning team to determine whether or not bed rails are indicated.
- Reassure patients and their families that in many cases the patient can sleep safely without bed rails.
- Reassess the need for using bed rails on a frequent, regular basis.

To report an adverse event or medical device problem, please call FDA's **MedWatch Reporting Program** at 1-800-FDA-1088.

For additional copies of this brochure, see the FDA's website at

<http://www.fda.gov/MedicalDevices/ProductsandMedicalProcedures/GeneralHospitalDevicesandSupplies/HospitalBeds/default.htm>

For more information about this brochure, contact Beryl Goldman at 610-388-5580 or by e-mail at bgoldman@kcorp.kendal.org. She has volunteered to answer questions.

For information regarding a specific hospital bed, contact the bed manufacturer directly.

Developed by the Hospital Bed Safety Workgroup

Participating Organizations:

- AARP
- ABA Tort and Insurance Practice Section
- American Association of Homes and Services for the Aging
- American Health Care Association
- American Medical Directors Association
- American Nurses Association
- American Society for Healthcare Engineering of the American Hospital Association
- American Society for Healthcare Risk Management
- Basic American Metal Products
- Beverly Enterprises, Inc.
- Care Providers of Minnesota
- Carroll Healthcare
- DePaul College of Law
- ECRI
- Evangelical Lutheran Good Samaritan Society
- Hill-Rom Co., Inc.
- Joint Commission on Accreditation of Healthcare Organizations
- Medical Devices Bureau, Health Canada
- National Association for Home Care
- National Citizens' Coalition for Nursing Home Reform
- National Patient Safety Foundation
- RN+ Systems
- Stryker Medical
- Sunrise Medical, Inc.
- The Jewish Home and Hospital
- Untie the Elderly, The Kendal Corporation
- U.S. Food and Drug Administration

October 2000 (Revised 4/2010)

A Guide to Bed Safety



Bed Rails In Hospitals, Nursing Homes and Home Health Care: The Facts



Bed Rail Entrapment Statistics

Today there are about 2.5 million hospital and nursing home beds in use in the United States. Between 1985 and January 1, 2009, 803 incidents of patients* caught, trapped, entangled, or strangled in beds with rails were reported to the U.S. Food and Drug Administration. Of these reports, 480 people died, 138 had a nonfatal injury, and 185 were not injured because staff intervened. Most patients were frail, elderly or confused.



Patient Safety

Patients who have problems with memory, sleeping, incontinence, pain, uncontrolled body movement, or who get out of bed and walk unsafely without assistance, must be carefully assessed for the best ways to keep them from harm, such as falling. Assessment by the patient's health care team will help to determine how best to keep the patient safe.

Historically, physical restraints (such as vests, ankle or wrist restraints) were used to try to keep patients safe in health care facilities. In recent years, the health care community has recognized that physically restraining patients can be dangerous. Although not indicated for this use, bed rails are sometimes used as restraints. Regulatory agencies, health care organizations, product manufacturers and advocacy groups encourage hospitals, nursing

homes and home care providers to assess

** In this brochure, the term patient refers to a resident of a nursing home, any individual receiving services in a home care setting, or patients in hospitals.*

patients' needs and to provide safe care without restraints.



The Benefits and Risks of Bed Rails

Potential benefits of bed rails include:

- Aiding in turning and repositioning within the bed.
- Providing a hand-hold for getting into or out of bed.
- Providing a feeling of comfort and security.
- Reducing the risk of patients falling out of bed when being transported.
- Providing easy access to bed controls and personal care items.

Potential risks of bed rails may include:

- Strangling, suffocating, bodily injury or death when patients or part of their body are caught between rails or between the bed rails and mattress.
- More serious injuries from falls when patients climb over rails.
- Skin bruising, cuts, and scrapes.
- Inducing agitated behavior when bed rails are used as a restraint.
- Feeling isolated or unnecessarily restricted.
- Preventing patients, who are able to get out of bed, from performing routine activities such as going to the bathroom or retrieving something from a closet.



Meeting Patients' Needs for Safety

Most patients can be in bed safely without bed rails. Consider the following:

- Use beds that can be raised and lowered close to the floor to accommodate both patient and health care worker needs.
- Keep the bed in the lowest position with wheels locked.
- When the patient is at risk of falling out of bed, place mats next to the bed, as long as this does not create a greater risk of accident.
- Use transfer or mobility aids.
- Monitor patients frequently.
- Anticipate the reasons patients get out of bed such as hunger, thirst, going to the bathroom, restlessness and pain; meet these needs by offering food and fluids, scheduling ample toileting, and providing calming interventions and pain relief.

When bed rails are used, perform an on-going assessment of the patient's physical and mental status; closely monitor high-risk patients. Consider the following:

- Lower one or more sections of the bed rail, such as the foot rail.
- Use a proper size mattress or mattress with raised foam edges to prevent patients from being trapped between the mattress and rail.
- Reduce the gaps between the mattress and side rails.

Clinical Guidance
For the Assessment and Implementation of
Bed Rails
In Hospitals, Long Term Care Facilities, and
Home Care Settings



Developed by the
Hospital Bed Safety Workgroup

Table of Contents

Preface.....	ii
Introduction.....	1
Guiding Principles.....	3
Policy Considerations.....	4
Process/Procedure Considerations.....	5
Risk Intervention.....	9
Individualized Environmental Changes.....	10
Patient Choice.....	10
Bed Rails as Restraints.....	10
Education /Training.....	10
Bed Rail Safety Guidelines.....	11
Appendix 1: Glossary.....	12
Appendix 2: Bed Rails - Intended Purpose and Potential Risks.....	14
Appendix 3: Bed Side Rail Types.....	15
Appendix 4: Hospital Bed Safety Workgroup Member Organizations that Signed on to the Clinical Guidance.....	17
Appendix 5: Authors.....	18

In April 1999, the Food and Drug Administration (FDA) in partnership with representatives from the hospital bed industry, national healthcare organizations, patient advocacy groups and other federal agencies formed the Hospital Bed Safety Workgroup. The workgroup's goal is to improve the safety of hospital beds for patients in all health care settings who are most vulnerable to the risk of entrapment. The workgroup is developing additional resources including dimensional guidelines, measurement tools, and educational materials to assist manufacturers, caregivers and consumers.

This clinical guidance is provided for discussion and educational purposes only and should not be used or in any way relied upon without consultation with and supervision of a qualified practitioner based on the case history and medical condition of a particular patient. The Hospital Bed Safety Workgroup, their heirs, executors, administrators, successors, and assigns hereby disclaim any and all liability for damages of whatever kind resulting from the use, negligent or otherwise, of this clinical guidance.

For information about the Hospital Bed Safety Workgroup, see the FDA's website at <http://www.fda.gov/cdrh/beds/>

Clinical Guidance For The Assessment and Implementation of Bed Rails In Hospitals, Long Term Care Facilities, and Home Care Settings

Introduction

Every patient, regardless of care setting, deserves a safe and comfortable sleeping and bed environment. The goal of this clinical guidance is the provision of such an environment to patients in hospitals, long term care facilities, and home care settings. (Note: The term *patient* as used in this document refers to patients in hospitals, residents in long term care facilities, and clients in home care settings.) The purpose of this guidance is to provide a uniform set of recommendations for caregivers in hospitals, long term care facilities, and home care settings to use when assessing their patients' need for and possible use of bed rails. The guidance is deliberately basic in design and content to allow each setting to adapt it to meet the unique needs of their respective patients and environments.

The guidance that follows is intended to assist caregivers in making decisions about the care for their patients. Its components are not intended to serve as clinical standards or requirements for care. They are not intended to serve as applicable federal, state or local regulations or guidelines governing care in respective settings. Likewise the recommendations should not be interpreted as the best or only options, professional standards of care, or legal protection for the users.

The term *bed rails* is used in this document. Commonly used synonymous terms are *side rails*, *bed side rails*, and *safety rails*. Bed rails are adjustable metal or rigid plastic bars that attach to the bed and are available in a variety of shapes and sizes from full to half, one-quarter, and one-eighth in lengths.¹ In the spectrum of care including hospital, long term care and home care settings, bed rails serve a variety of purposes, some of which are in the best interest of the patient's health and safety. Bed rails:

- are used on stretchers or beds while transporting patients following surgery or when relocating a patient to a new room or unit;
- can facilitate turning and repositioning within the bed or transferring in or out of a bed;
- may provide a feeling of comfort and security, or facilitate access to bed controls; and
- may be used as a physical barrier to remind the patient of the bed perimeters, to ask for nursing assistance, or to restrict voluntary movement out of bed.^{2,3}

Achieving the goal of a safe and comfortable bed and sleeping environment may necessitate the reduction or elimination of bed rail use in cases in which the bed rail is not in the best interests of the patient's health and safety.

¹ Capezuti, E. & Lawson, WT III (1999). Falls and restraint liability issues. In P. Iyer (Ed.) Nursing Home Litigation: Investigation and Case Preparation. Tucson, AZ: Lawyers and Judges Publishing Company.

² Braun, J.A. & Capezuti, E. (2000). The legal and medical aspects of physical restraints and bed side rails and their relationships to falls and fall-related injuries in nursing homes. DePaul Journal of Healthcare Law, 3 (1) 1-72.

³ Capezuti, E., Talerico, K.A., Cochran, I., Becker, H., Strumpf, N., & Evans, L. (1999). Individualized interventions to prevent bed-related falls and reduce side rail use. Journal of Gerontological Nursing, 25, 26-34.

Although various types may be used depending on a patient's medical and functional needs, bed rails may pose increased risk to patient safety. Clinical research suggests that bed rails may not be benign safety devices. For example, evidence indicates that half-rails pose a risk of entrapment and full rails pose a risk of entrapment as well as falls that occur when patients climb over the rails or footboards when the rails are in use.^{4,5} Recognizing this risk, the U.S. Food and Drug Administration (FDA) and Centers for Medicare & Medicaid Services (CMS), formerly known as the Health Care Financing Administration (HCFA), have taken action aimed at reducing the likelihood of injuries related to bed rails. The FDA MedWatch Reporting Program receives reports of entrapment hazards.⁶ In 1995 the FDA issued a Safety Alert entitled, "*Entrapment Hazards with Hospital Bed Side Rails.*"⁷ In 1997, the FDA authored an article, based on the reported hospital bed adverse events, that identified potential risk factors and entrapment locations about the hospital bed. The FDA continues to receive reports of patient deaths and injury that provide documentation of patient entrapment.⁸

CMS has imposed performance expectations on hospitals and nursing facilities. For example, in implementing federal regulations that apply to the use of physical restraints, CMS issued guidance in June 2000 for surveyors to determine hospitals' compliance with these regulations. One section of the guidance states, "*It is important to note that side rails present an inherent safety risk, particularly when the patient is elderly or disoriented. Even when a side rail is not intentionally used as a restraint, patients may become trapped between the mattress or bed frame and the side rail. Disoriented patients may view a raised side rail as a barrier to climb over, may slide between raised, segmented side rails, or may scoot to the end of the bed to get around a raised side rail. When attempting to exit the bed by any of these routes, the patient is at risk for entrapment, entanglement, or falling from a greater height posed by the raised side rail, with a possibility for sustaining greater injury or death than if he/she had fallen from the height of a lowered bed without raised siderails.*"⁹

In September 2000 CMS (then HCFA) issued revisions to surveyor guidance for determining nursing facilities' compliance with federal Medicare and Medicaid regulations governing the use of restraints, which similarly describes the potential risks of using bed rails.¹⁰ For example, the guidance states, "*The same device may have the effect of restraining one individual, but not another, depending on the individual resident's condition and circumstances. For example, partial rails may assist one resident to enter and exit the bed independently while acting as a restraint for another.*"

⁴Parker, K., Miles, SH. (1997). Deaths caused by bed rails. *Journal of the American Geriatrics Society* 45:797-802.

⁵Feinsod, F.M., Moore, M., Levenson, S. (1997). Eliminating full-length bed rails from long term care facilities. *Nursing Home Medicine* 5:257-263.

⁶MedWatch, the U.S. Food and Drug Administration's medical products reporting program.

⁷Food and Drug Administration. FDA Safety Alert: Entrapment Hazards with Hospital Bed Side Rails (Aug 23, 1995). U.S. Department of Health and Human Services.

⁸Todd, J., Ruhl, C., & Gross, T. (1997). Injury and Death Associated with Hospital Bed Side-Rails: Reports to the U.S. Food and Drug Administration from 1985 to 1995. *American Journal of Public Health* 87 (10): 1675-1677.

⁹Health Care Financing Administration guidance to surveyors in the implementation of 42 CFR Part 482 Medicare and Medicaid Programs. State Operations Manual Provider Certification Transmittal 17. June 2000. A-182-183.

¹⁰Health Care Financing Administration guidance to surveyors in the implementation of 42 CFR Part 483.13(a). Medicare and Medicaid Programs. State Operations Manual Provider Certification Transmittal 20. September 7, 2000. PP-45.

Guiding Principles

National surveys of patient deaths occurring in the bed environment demonstrate the risk of entrapment when a patient slips between the mattress and bed rail or when the patient becomes entrapped in the bed rail itself. The population at risk for entrapment are patients who are frail or elderly or those who have conditions such as agitation, delirium, confusion, pain, uncontrolled body movement, hypoxia, fecal impaction, and acute urinary retention that cause them to move about the bed or try to exit from the bed. The absence of timely toileting, position change, and nursing care are factors that may also contribute to the risk of entrapment. The risk may also increase due to technical issues such as the mis-sizing of mattresses, bed rails with winged edges, loose bed rails, or design elements such as wide spaces between vertical bars in the rails themselves.

The principles that follow are intended to guide the development of patients' care plans.

1. The automatic use of bed rails may pose unwarranted hazards to patient safety. When planning patient care the following should be considered:
 - The potential for serious injury is more likely to be related to a fall from a bed with raised bed rails when the patient attempts to climb over, around, between, or through the rails, or over the foot board, than from a bed without rails in use.
 - Evaluation is needed to assess the relative risk of using the bed rail compared with not using it for an individual patient.
 - Bed rails sometimes restrain patients. When used as restraints, bed rails can pose the same risk to patient safety as other types of physical restraints.
 - Patient safety is paramount. In an emergent situation the caregiver needs to do whatever is necessary in his or her professional judgment to secure the patient's safety. Consider that using a bed rail or other device to restrain the patient could place the patient's safety at risk.
 - Physical restraints such as vest/chest, waist, or leg/arm restraints used simultaneously with raised bed rails may be medically indicated in certain limited circumstances in the acute care environment. Consider that when physical restraints and bed rails are used simultaneously:
 - the risk to patient safety, e.g., suffocation or accidental suspension, may increase;
 - patients should be monitored closely;
 - appropriate care such as toileting should be provided; and
 - reassessment for medical necessity and removal is needed on a regular basis.
 - Strangling, suffocating, bodily injury, or death can occur when patients or parts of their bodies are caught between rails or between the bed rails and mattresses.
2. Decisions to use or to discontinue the use of a bed rail should be made in the context of an individualized patient assessment using an interdisciplinary team with input from the patient and family or the patient's legal guardian.

3. The patient's right to participate in care planning and make choices should be balanced with caregivers' responsibility to provide care according to an individual assessment, professional standards of care, and any applicable state and federal laws and regulations.

Policy Considerations

1. Regardless of the purpose for which bed rails are being used or considered, a decision to utilize or remove those in current use should occur within the framework of an individual patient assessment.
2. Because individuals may differ in their sleeping and nighttime habits, creation of a safe bed environment that takes into account patients' medical needs, comfort, and freedom of movement should be based on individualized patient assessment by an interdisciplinary team.
 - The composition of the interdisciplinary team may vary depending upon the nature of the care and service setting and the patient's individual needs. Team members for consideration should include, but are not limited to: nursing, social services, and dietary personnel; physicians (or their designees); medical director; rehabilitation and occupational therapists; patient; family (or authorized representative); and medical equipment suppliers.
 - The patient and family (or authorized representative) play a key role in the creation of a safe and comfortable bed and sleeping environment. These individuals can provide information about the patient's previous sleeping habits and bed environment that caregivers need to design the bed environment. Their participation in discussions facilitates creation of a bed and sleeping environment that meets patients' needs.
3. Use of bed rails should be based on patients' assessed medical needs and should be documented clearly and approved by the interdisciplinary team.
 - Bed rail effectiveness should be reviewed on a regular basis.
 - The patient's chart should include a risk-benefit assessment that identifies why other care interventions are not appropriate or not effective if they were previously attempted and determined not to be the treatment of choice for the patient. (See Appendix 1: Glossary for patient/caregiver assist items.)
4. Bed rail use for treatment of a medical symptom or condition should be accompanied by a care plan (treatment program) designed for that symptom or condition.
 - The plan should present clear directions for further investigation of less restrictive care interventions.
 - The documentation should describe the attempts to use less restrictive care interventions and, if indicated, their failure to meet patients' assessed needs.
5. Bed rail use for patient's mobility and/or transferring, for example turning and positioning within the bed and providing a hand-hold for getting into or out of bed, should be accompanied by a care plan.
 - The patient should be encouraged to participate in care planning to help design a safe and comfortable bed environment.

- The care plan should:
 - include educating the patient about possible bed rail danger to enable the patient to make an informed decision; and
 - address options for reducing the risks of the rail use.
6. The process of reducing and/or eliminating existing use of bed rails should be undertaken incrementally using an individualized, systematic, and documented approach.
 7. Creating a safe bed environment does not necessarily preclude the use of bed rails. However, a decision to use them should be based on a comprehensive assessment and identification of the patient's needs, which include comparing the potential for injury or death associated with use or non-use of bed rails to the benefits for an individual patient. In creating a safe bed environment, the following general principles should be applied:
 - Avoid the *automatic* use of bed rails of any size or shape.
 - Restrict the use of physical restraints, including chest, abdominal, wrist, or ankle restraints of any kind on individuals in bed.
 - Inspect, evaluate, maintain, and upgrade equipment (beds/mattresses/bed rails) to identify and remove potential fall and entrapment hazards and appropriately match the equipment to patient needs, considering all relevant risk factors.
 - Re-assess the patient's needs and re-evaluate the equipment if an episode of entrapment or near-entrapment occurs, with or without serious injury. This should be done immediately because fatal "repeat" events can occur within minutes of the first episode.

Process/Procedure Considerations

The items listed below are not meant to be all-inclusive. Caregivers may identify other concerns that need to be addressed.

1. Individualized Patient Assessment

Any decision regarding bed rail use or removal from use should be made within the framework of an individual patient assessment. If a bed rail has been determined to be necessary, steps should be taken to reduce the known risks associated with its use. The individual patient assessment includes^{11 12 13 14 15 16 17 18} , , , , , , , ,

¹¹ Capezuti, E., Talerico, K.A., Strumpf, N., & Evans, L. (1998). Individualized assessment and intervention in bilateral side rail use. *Geriatric Nursing*, 25, 26-34.

¹² See Capezuti et al., *supra* note 1.

¹³ Donius, M. & Rader, J. (1994) Use of Side rails: Rethinking a Standard of Practice, *Journal of Gerontological Nursing* 23, 23-27.

¹⁴ Rader, J. (1995). Creating a supportive environment for eliminating restraints. In Rader, J. & Tornquist, E.M. (Eds.) *Individualized Dementia Care*, New York: Springer Publishing Company.

¹⁵ Donius, M., & Rader, J. (1996). Side rails: Rethinking a Standard Practice. In Burggraf, V. & Barry, R. (Eds.), *Gerontological Nursing Current Practice and Research*. Thorofare, NJ: Slack, Inc.

¹⁶ O'Keeffe, S., Jack, C.I.A., & Lye, M. (1996). Use of restraints and bed rails in a British hospital. *Journal of the American Geriatrics Society*, 44, 1086-1088.

¹⁷ Frengley, J.D. (1999), Bedrails: Do They Have A Benefit?, *Journal of the American Geriatrics Society*, 47(5): 627-628.

¹⁸ Hammond, M., Levine, J.M. Bedrails: Choosing the Best Alternative. *Geriatric Nursing*. 20(6):297-300. 1999 Nov. – Dec.

- Medical diagnosis, conditions, symptoms, and/or behavioral symptoms
- Sleep habits
- Medication
- Acute medical or surgical interventions
- Underlying medical conditions
- Existence of delirium
- Ability to toilet self safely
- Cognition
- Communication
- Mobility (in and out of bed)
- Risk of falling

2. Sleeping environment assessment

This assessment includes elements or conditions that may affect the patient's ability to sleep and may be considered in evaluating areas to address in a patient's care plan.

- Comfort
 - pain
 - hypoxia
 - grieving
 - loneliness
 - hunger, thirst
 - hydration
 - calorie intake and protein calories
 - boredom
 - amount of time spent in bed
 - light levels
 - temperature
- Understanding of self and family
 - hobbies, interests, religion
 - pictures of family
- Proximity to toilet
 - toilet within view
 - toilet accessible
 - strategy (patient with or without help from caregiver) for toileting
- Appropriate bed
 - comfortable
 - safe
 - height
 - mattress/overlay
 - mattress edge definition (if necessary)
 - support for turning (if necessary)

- strategy for safe egress
- elevation for head of bed
- Support by Caregivers
 - individualized toileting schedule
 - routine comfort assessment
 - skin care and hygiene
 - emotional and physical support
- Medical Stabilization
 - treatment of underlying acute medical problems
 - dosages and types of medication
 - effects of long-term use of hypnotics
 - pain treatment strategy
 - caution with orthostatic medications (diuretics, short-acting antihypertensives)
 - diuretics (if indicated) not given at night
 - diabetic snack given at night
 - treatment for nocturnal esophageal reflux
 - bowel elimination plan for regularity

3. Treatment Programs/Care Plans

- Address diagnoses, symptoms, conditions, and/or behavioral symptoms for which the use of a bed rail is being considered.
- Identify nursing/medical and environmental interventions (e.g., for a patient with a life-long habit of staying up at night, provide nighttime activity).
- If clinical and environmental interventions have proven to be unsuccessful in meeting the patient's assessed needs or a determination has been made that the risk of bed rail use is lower than that of other interventions or of not using them, bed rails may be used. Documentation of the risk-benefit assessment should be in the patient's medical chart.
- The team should review the treatment program and determine its effects on the patient through an ongoing cycle of evaluation that includes assessment of outcomes and adverse effects.
- When planning care for the patient for whom a low bed is selected, consideration should be given to potential effects on the patient such as restraining desired voluntary movement or creating an unwanted psychological effect by being placed close to the floor. The individualized care plan and risk benefit considerations should address these issues and the plan modified accordingly.
- General guidance:
 - a. A patient is assessed to be at low risk for injury, as defined by these factors:
 - transfers safely to and from the bed to a wheelchair without assistance;
 - ambulates without assistance to and from the toilet without falling;
 - has not fallen, or is unlikely to fall, out of bed; and
 - notifies staff appropriately using call system.

Consider using a bed for this patient without a bed rail.

- b. A patient is assessed to be unsafe in bed, or at high risk for injury, as defined by these factors:
- inability to transfer safely to and from the bed to a wheelchair;
 - previous entrapment or near-entrapment episode;
 - inability to ambulate to and from the toilet without falling;
 - history of bed-related serious injury;
 - episodes of falling out of bed, or likelihood that such episodes will occur; or
 - inconsistent in notifying staff of needs or unable to access the call system.
- Consider placing this patient in an adjustable height bed that can go very low to the floor for sleeping and raised for transfers and activities of daily living care, or an alternative such as a concave mattress as determined by the interdisciplinary care team. Use a high-impact mat next to the bed.*
- c. A patient is assessed to require a bed in a low position but has difficulty getting into the low bed from the standing position:
- Consider an adjustable-height bed. If this is not available, consider adding a quarter rail or transfer device (See Appendix 1: Glossary) to a low bed for the patient to hold for support while entering the low bed. When selecting a support hold, consider:*
- Such rails should contain cross bars close enough to prevent the passage of the patient's head or body part through the rail and fit closely enough to the mattress to prevent entrapment.
 - Other interventions exist, such as secured vertical poles used for transferring in and out of bed. These poles, which are secured into the ceiling and floor, have weight limits. Tape applied to the pole may increase traction. They are generally used with more cognitively functional individuals.
- d. A patient is assessed to need a low bed, but an assessment determines that the patient is in danger of hurting him/herself while exiting from the low bed or is in danger of an unstable transfer after standing up by grabbing onto a bed side table or sink:
- Consider using a bed alarm to alert nursing staff when patient is leaving the bed.*
- Base the decision on the individual patient's clinical condition and assessment.
 - Carefully consider the use of bed alarms for the patient who is agitated or confused.
- e. Steps should be taken to reduce risk of injury to patients and caregivers. Keep the bed in the lowest position with the wheels locked when occupied, adjusting the level for activities such as administering care or for patient transfers in/out of bed:
- Place a high impact mat next to the low bed to cushion falls from the low bed as long as this does not create a greater risk of accident to the patient or caregivers.
 - Raise the bed to give care and lower it when finished. If the bed is not adjustable, utilize body mechanics techniques such as kneeling on one or both knees on the high impact mat rather than bending over.
 - Store the high impact mat when it is not in use.
 - Assess area for objects that may cause injury.
 - Move furniture far enough away from the bed to avoid risk of injury.
 - Train caregivers on the proper use of low beds and proper body mechanics.

Risk Intervention

Assessment of risk should be part of the individual patient's assessment, and steps to address the risk should be incorporated into the patient's care plan. The following are examples of risk intervention approaches.

1. Nursing

- Provide individually scheduled toileting.
- Develop a schedule for turning and positioning.
- Clean urine and/or feces promptly.
- Elevate head of bed for patients with congestive heart failure (CHF), chronic obstructive pulmonary disease (COPD), reflux, and actively infusing enteral fluids.
- Position patients to maximize comfort and change positions in a timely manner, maintaining comfort and reducing risk for skin breakdown.
- Accommodate patients' preferred bedtime habits whenever possible.
- Restrict use of physical restraints on patients in bed.
- When medically indicated, use padded bed rails for individuals with an active seizure disorder or active movement disorder.
- Provide distractions such as music, television, or food and fluids for patients who do not sleep through the night.
- Provide calming interventions and pain relief.
- Plan time during the day to provide periods of physical activity that help promote a restful sleep.
- Re-evaluate and revise patient's treatment program as needed if an episode of entrapment or near-entrapment occurs with or without serious injury.

2. Medical

- Minimize use of medications that alter mental status.
- Use alternatives to sleeping medications.
- Dispense diuretics before the late afternoon/evening.
- Treat pain.
- Screen and treat for hypoxia.
- Assess the clinical status of delirious patients to rule out reversible etiologies.
- Promote mobility and fitness, e.g., restorative care to enhance abilities to stand safely and to walk.

3. Patient and Family

- Seek and utilize input about the patient from the patient and family (or authorized representative) to assist in identifying nursing and medical risk interventions.
- If patients or family members ask about using bed rails, encourage them to talk to the health care team about whether bed rails are indicated.
- Since the patient and family are integral members of the team, they should be encouraged to learn about bed safety and appropriate care options.

Individualized Environmental Changes

The environmental changes listed below are suggestions for consideration. Whether they will be used for an individual patient depends on the patient's assessment.

1. Use of low beds with adjacent mat on the floor (with consideration given to using mechanical lifts and proper lift technique training for caregiver staff).
2. Use of low beds that can be elevated electronically for transfer and activities of daily living (ADL) care.
3. Placement of the patient's call bell within easy reach and provision of visual and verbal reminders to use the call bell when necessary.
4. Use of bed alarms to warn of patients' attempts to exit from bed.
5. Use of "perimeter reminders" or "border definers" such as body pillow/cushions or mattresses with lipped/raised edges.
6. Use of a trapeze affixed to bed to increase patient's bed mobility. (For patients with shoulder conditions, trapeze use should be carefully scrutinized.)
7. Placement of inconspicuous signs, without patients' names, to inform caregivers of interdisciplinary care team recommendations.

Patient Choice

As with any other device that may be used as a restraint, if a patient, family member, or authorized representative requests the inappropriate use of side rails, then the interdisciplinary care team has a responsibility to discuss the risks involved, as well as the benefits of any clinical and/or environmental interventions that may be safer in meeting the patient's assessed needs, individual circumstances, and environment. The patient's right to participate in care planning and make choices should be balanced with caregivers' responsibility to provide care according to an individual assessment, professional standards of care, and any applicable state and federal laws and regulations.

Bed Rails as Restraints

When bed rails have the effect of keeping a patient from voluntarily getting out of bed, they fall under the definition of a physical restraint. If they are not necessary to treat medical symptoms, and less restrictive interventions have not been attempted and determined to be ineffective, bed rails used as restraints should be avoided.^{19,20} Bed rails used on the bed of a patient who is completely immobile do not serve as restraints, but may not be medically necessary. It is recommended that they be avoided.

Education /Training

Hospitals, long term care facilities, and home health care providers should provide education and training about bed rail use to assist in creating and implementing a safe and comfortable sleeping environment for their patients. It is recommended that the education and training be directed toward the following groups:

¹⁹ See Health Care Financing Administration *supra* note 10.

²⁰ See Health Care Financing Administration *supra* note 7 at A-182.

- Staff
- Patient/family
- Physicians, including medical directors and physician extenders such as physician assistants and nurse practitioners
- Long term care ombudsman
- Regulatory agencies or representatives

Bed Rail Safety Guidelines

If it is determined that bed rails are required and that other environmental or treatment considerations may not meet the individual patient's assessed needs, or have been tried and were unsuccessful in meeting the patient's assessed needs, then close attention must be given to the design of the rails and the relationship between rails and other parts of the bed.

1. The bars within the bed rails should be closely spaced to prevent a patient's head from passing through the openings and becoming entrapped.
2. The mattress to bed rail interface should prevent an individual from falling between the mattress and bed rails and possibly smothering.
3. Care should be taken that the mattress does not shrink over time or after cleaning. Such shrinkage increases the potential space between the rails and the mattress.
4. Check for compression of the mattress' outside perimeter. Easily compressed perimeters can increase the gaps between the mattress and the bed rail.
5. Ensure that the mattress is appropriately sized for the selected bed frame, as not all beds and mattresses are interchangeable.
6. The space between the bed rails and the mattress and the headboard and the mattress should be filled either by an added firm inlay or a mattress that creates an interface with the bed rail that prevents an individual from falling between the mattress and bed rails.
7. Latches securing bed rails should be stable so that the bed rails will not fall when shaken.
8. Older bed rail designs that have tapered or winged ends are not appropriate for use with patients assessed to be at risk for entrapment.
9. Maintenance and monitoring of the bed, mattress, and accessories such as patient/caregiver assist items (See Appendix 1: Glossary) should be ongoing.

Appendix 1: Glossary

Adjustable height bed – A bed with “hi-low” function such that the height of the sleep surface can be adjusted.

Automatic contour - A feature of a bed where the thigh section of the sleep surface articulates upward as the head section travels upward thereby reducing the likelihood of patient/resident mattress from migrating toward the foot end of the bed.

Bed alarms – Alarms intended to notify caregivers of either an unwanted patient/resident egress or that the patient/resident is near the edge of the mattress.

Bed rail extender – A detachable device intended to bridge the space between the head and foot bed rail.

Bed rails –Adjustable metal or rigid plastic bars that attach to the bed. They are available in a variety of types, shapes, and sizes ranging from full to one-half, one-quarter, or one-eighth lengths. Synonymous terms are *side rails*, *bed side rails*, and *safety rails*. (See attached *Bed Side Rail Types* for illustrated definitions.)

Control bed rail – A bed rail that incorporates bed function controls for patient/staff activation.

Fireman’s pole – A pole secured (floor and ceiling mooring) next to the bed that acts as a support for the patient to get into and out of the bed.

Handgrips – Devices attached to either side of the bed to provide the patient/resident the ability to reposition themselves while in bed as well as an aid to enter and leave the bed.

High-impact mat (bed-side mat) – A mat placed next to the bed that absorbs the shock if the patient falls from the bed.

Entrapment – An event in which a patient is caught, trapped, or entangled in the spaces in or about the bed rail, mattress, or hospital bed frame. Entrapment can result in serious injury or death.

Interdisciplinary team -- The interdisciplinary team may vary in constituency depending upon the nature of the care and service setting and the individual patients’ needs. Members may include, but are not limited to: patient; family member (or patient’s legal representative); nursing, social services, and dietary personnel; attending physician (or designee); medical director; rehabilitation and occupational therapists; and medical equipment suppliers.

Lifting pole – A device suspended above the bed intended to allow the patient to change position by gripping it.

Low bed – This bed is defined according to the patient: The bed is considered “low” if, when the patient is sitting on the side of the bed with feet on the floor, the angle of the patient’s bent knees is 90 degrees or less.

Mattress with raised edges – A mattress that has a perimeter configured in a manner to allow the patient/resident to be “cradled” in the center of the mattress and reduces the likelihood of unwanted patient egress. It has a central area on either side of the mattress that is not raised and is used for egress.

Patient assessment – The assessment provides ongoing information necessary to develop a care plan, to provide the appropriate care and services for each patient, and to modify the care plan and care/services based on the patient's status. Details about the components of the assessment are found on pages 5 and 6 of this document.

Pediatric rail – A rail in which the bar spacing is no larger than two and three-eighths inches.

Pendant control – A means used by either the patient or the operator to control the drives that activate various bed functions and is attached to the bed by a cord.

Physical restraint – Any manual method or physical or mechanical device, material, or equipment attached or adjacent to the resident's [patient's] body that the individual cannot remove easily that restricts freedom of movement or normal access to one's body. (Source: Health Care Financing Administration State Operations Manual, Rev. 274, Guidance to Surveyors at 42 CFR Subpart B, Requirements for Long Term Care Facilities, 483.13(a).)

Sleeping environment – Includes physical components such as the bed size and height and mattress, the accessibility of personal items and accessories such as a call bell, and the room temperature and noise or light levels. The environment also includes nonphysical aspects such as comfort and security. These aspects may be related to the physical features of the bed such as the degree of mattress firmness, or features that facilitate freedom from physical pain, or a feeling of safety and privacy.

Transfer device - Support for transfers such as half - or quarter-length upper bed rails, bed grab bars, bed handles attached to the bed frame, or fireman's transfer pole.

Treatment program (care plan) – The treatment program includes measurable objectives and timetables to meet the patient's medical, nursing, and mental and psychosocial needs that are identified through the assessment process. The effectiveness of the treatment program is evaluated and modified as necessary. The interdisciplinary team reviews, revises, and initiates changes to the program as needed in accordance with professional standards of practice after each assessment.

Seizure pads - Padded covers for bed rails that may be used to prevent unwanted patient/resident cuts and bruising from repeated contact with the bed rails. Also used to cover openings within the perimeter of the side rails and space between the head and foot rails.

Side rails – See *Bed rails*.

Stuff pads – Plastic covered pads used to obliterate open spaces between bed rails and mattresses, mattresses and head/foot boards.

Transfer bar – A one-piece device, attached to the bed frame on one or both sides of the bed, that is grasped to aid in bed entry and exit.

Appendix 2: Bed Rails - Intended Purpose and Potential Risks

Intended Purpose of Bed Rails

1. One of several methods utilized to prevent patient from falling out of bed.
 - Reminds patient not to get out of bed when medically contraindicated and/or medical equipment is attached to the patient.
 - Defines the bed edge.
 - Helps to protect patient from falling out of bed during transport.
2. May assist patient with movement.
 - Moving within the bed.
 - Getting in and out of bed.
3. One of several methods to provide the patient with easy access to bed controls.
4. One of several methods to provide a feeling of comfort and security.

Potential Risks of Bed Rails

1. Create a source of known morbidity and mortality such as:
 - Strangling, suffocation, serious bodily injury,* or death when patients or parts of their bodies are caught between rails, the openings of the rails, or between the bed rails and mattress.
2. Impede patients from safely getting out of bed:
 - Patients crawl over rails and fall from greater heights increasing the risk for serious injury.
 - Patients attempt to get out of bed over the foot board.
3. Restrain patients in many circumstances:
 - Hinder patients from independently getting out of bed thereby confining them to their beds.
 - Create a barrier to performing routine activities such as going to the bathroom.
4. Can create negative psychological effects:
 - Create undignified personal image.
 - Alter patient self-esteem.
 - Contribute to patient isolation.
 - Confinement can cause patients to be incontinent.

The potential risks can be exacerbated by:

- Improper match of the bed rail to bed frame.
- Improper installation.
- Objects such as holders or supports that remain when the bed rail is removed.

* May include head trauma; bruising, contusions, and/or skin lacerations; and fractures and/or dislocations.

Appendix 3: Bed Side Rail Types

The drawings below are intended only to illustrate the design of bed rails. They are not intended to represent actual or recommended dimensions.

Full-Length Rail: A one-piece rail that extends along the side of the bed from the head to the foot section.



¾-Length Rail: A one-piece rail that extends along the side of the bed three-quarters of the way down from the head of the bed.

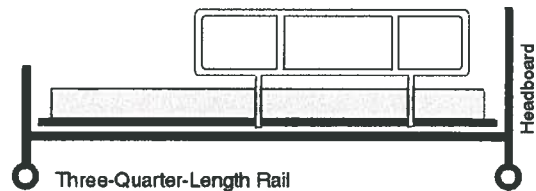

Half-Length Rail: A one-piece rail that extends along the side of the bed one-half the length of the bed from the head of the bed.

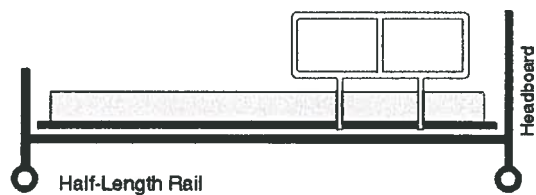

Quarter-Length Rail: A one-piece rail that extends along the side of the bed approximately $\frac{1}{4}$ the length of the bed from the head of the bed.

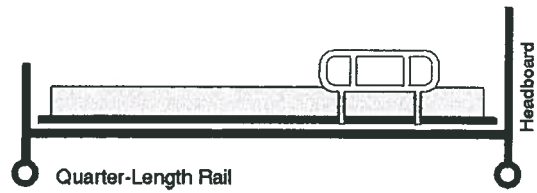

Split Rails: A pair of half rails. One set extends along the side of the bed from the head of the bed to the mid-section of the bed. The other set extends from the mid-section of the bed to the foot of the bed. Generally, there is a space between the two sets of rails.

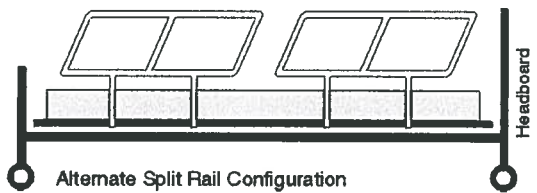
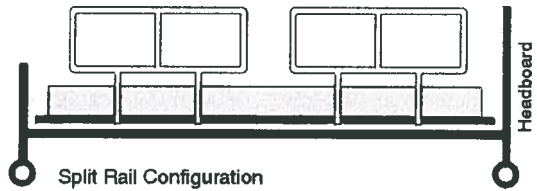

Transfer Bar: A one-piece device, attached to the bed frame on one or both sides of the bed, that is grasped to aid in bed entry and exit.

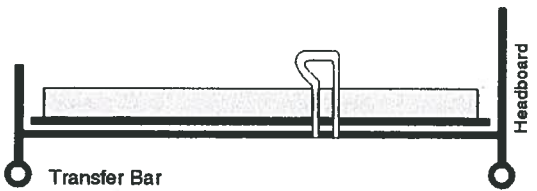
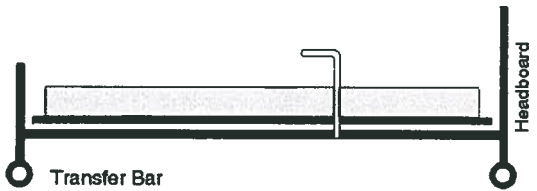

D012Y9A-07

Appendix 4: Hospital Bed Safety Workgroup Member Organizations that Signed on to the Clinical Guidance

AARP
American Association of Homes and Services for the Aging
American Health Care Association
American Medical Directors Association
American Nurses Association
American Society of Healthcare Risk Management
Basic American Metal Products
Care Providers of Minnesota
Carroll Health Care
ECRI
Evangelical Lutheran Good Samaritan Society
Hard Manufacturing
Health Safe, Incorporated
Iona Senior Services
Kinetic Concepts Incorporated
Law Offices of Julie A. Braun
MC Healthcare
Medical Devices Bureau, Health Canada
National Association of Home Care
National Patient Safety Foundation
National Citizens Coalition for Nursing Home Reform
Orange Grove Habilitation Center
RN Systems +
Span American
Sunrise Medical
Tactilics, Inc.
Untie the Elderly, The Kendal Corporation
U.S. Food and Drug Administration
Vail Products, Incorporated
Veterans Administration National Center for Patient Safety

HBSW member, the Joint Commission on Accreditation of Healthcare Organizations (JCAHO) has determined that the Clinical Guidance does not conflict with current standards in the JCAHO *Comprehensive Accreditation Manual for Hospitals 2002*, *2002 Standards Manuals for Home Care*, or the *2002-2003 Comprehensive Accreditation Manual for Long Term Care*.

Appendix 5: Authors

Doug Beardsley
Administrator/CEO
Valley Hospital at Hidden Lakes
Golden Valley, Minnesota

Mary Bias
Vice President
Hard Manufacturing Company
Buffalo, New York

Sarah Greene Burger, RNC, MPH
National Citizens' Coalition for Nursing Home Reform
Washington, DC

Elizabeth Capezuti, PhD, RN, CS, FAAN
Associate Professor
Independence Foundation Wesley Woods Chair in Gerontologic Nursing
Nell Hodgson Woodruff School of Nursing
Emory University
Atlanta, Georgia

Fred M. Feinsod, MD, MPH, CMD
American Medical Directors' Association
Colorado Springs, Colorado

Rita Munley Gallagher, PhD, RN, C
Senior Policy Fellow
Department of Nursing Practice and Policy
American Nurses Association
Washington, DC

Beryl Goldman, RN, MS, NHA
Director for Health Services
The Kendal Corporation
Kennett Square, Pennsylvania

Doni Haas, RN, LHRM
National Patient Safety Foundation
Stuart, Florida

Stephanie B. Hoffman, PhD
Director, Interprofessional Team Training and Development
Department of Veterans Affairs
James A. Haley Veterans Hospital
Tampa, Florida

Bill Kubat, MA
Vice President for Care Management, Clinical and Quality Affairs
Evangelical Lutheran Good Samaritan Society
Sioux Falls, South Dakota

Evvie Munley
Senior Health Policy Analyst
American Association of Homes & Services for the Aging
Washington, DC

Janet Myder, MPA
Director of Regulatory Systems
American Health Care Association
Washington, DC

Mary Lou Pijar
Public Health Advisor
Office of Health and Industry Programs
Center for Devices and Radiological Health
U.S. Food and Drug Administration
Rockville, Maryland

Georgene Saliba (through 2001)
American Society of Healthcare Risk Management
Lehigh Valley Hospital
Allentown, Pennsylvania

Paul English Smith, JD, CPHRM, ASHRM
American Society of Healthcare Risk Management
Vice President and General Counsel
Cabell Huntington Hospital, Inc.
Huntington, West Virginia

Joan Ferlo Todd
Senior Nurse Analyst
Office of Surveillance and Biometrics
Center for Devices and Radiological Health
U.S. Food and Drug Administration
Rockville, Maryland