

IVC™ Bariatric Bed

BAR600IVC

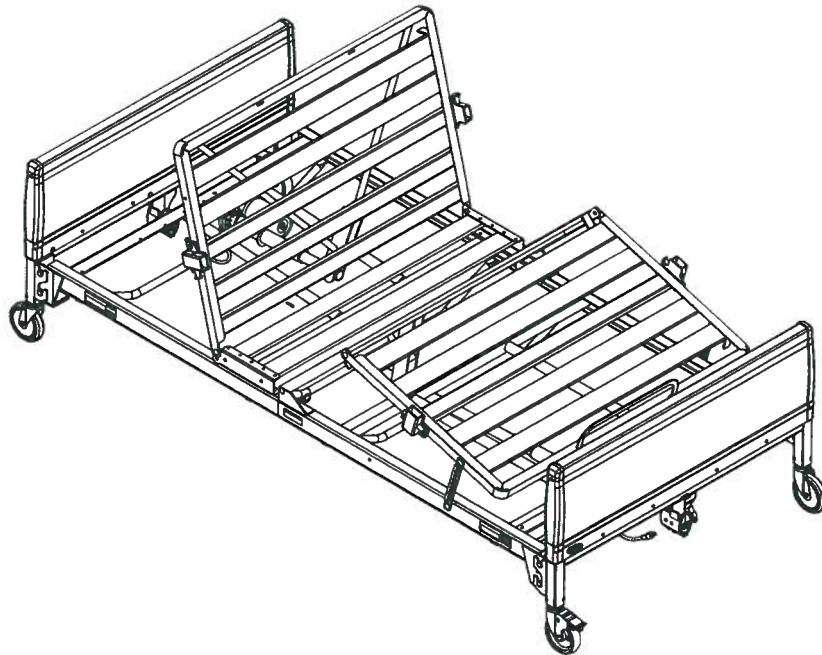

USER: Before using this product, read this manual and save for future reference.

DEALER: This manual **MUST** be given to the user.

For more information regarding
Invacare products, parts, and services,
please visit www.invacare.com



Yes, you can:

⚠ WARNING

DO NOT use this product or any available optional equipment without first completely reading and understanding these instructions and any additional instructional material such as owner's manuals, service manuals or instruction sheets supplied with this product or optional equipment. If you are unable to understand the warnings, cautions or instructions, contact a healthcare professional, dealer or technical personnel before attempting to use this equipment - otherwise, injury or damage may occur.

The initial set up of this bed must be performed by a qualified technician.

Procedures other than those described in this manual must be performed by a qualified technician.

For Dealers Only - Set-up and Assembly Instructions are in the rear of this manual. These procedures must be performed by a qualified technicians only.

⚠ ACCESSORIES WARNING

Invacare products are specifically designed and manufactured for use in conjunction with Invacare accessories. Accessories designed by other manufacturers have not been tested by Invacare and are not recommended for use with Invacare products.

SPECIAL NOTE

For your convenience, the March 2006 version of the FDA's bed safety guidelines are provided in the Appendix. The information from the FDA's brochure, published by Hospital Bed Safety Workgroup, is reproduced verbatim, the latest revision of which is available at <http://www.fda.gov>.

NOTE: Updated versions of this manual are available on www.invacare.com.

TABLE OF CONTENTS

REGISTER YOUR PRODUCT 5

SPECIAL NOTES 6

TYPICAL PRODUCT PARAMETERS 7

LABEL LOCATIONS 8

SECTION 1—GENERAL GUIDELINES 10

 Important Safety Instructions 10

 Operating Information..... 10

 Replacement Parts/Accessories 12

 Electrical 13

 Repair or Service Information..... 13

 Grounding Instructions..... 14

 Radio Frequency Interference 14

 Weight Limitations 14

SECTION 2—OPERATION AND ADJUSTMENT 15

 Operating Bariatric Bed 15

 Operating Bariatric Bed..... 15

 Raising and Lowering Entire Bed 16

 Raising and Lowering Head and Foot Sections 16

 Emergency Crank 17

 Optional Bed Rails..... 17

SECTION 3—MAINTENANCE 18

 Washing Bed Ends 18

 Cleaning Head and Foot Sections 18

 Maintenance and Cleaning Checklist..... 19

 Cleaning and Disinfecting Bed..... 19

 Mechanical Inspection and Maintenance..... 19

 Electrical Inspection and Maintenance 19

 PASS/FAIL 19

SECTION 4—TROUBLESHOOTING 20

 Troubleshooting: Electrical..... 20

 Troubleshooting: Mechanical 20

TABLE OF CONTENTS

**ASSEMBLY, MAINTENANCE AND ADJUSTMENT SECTIONS -
FOR DEALERS ONLY 21**

- Overview of Procedures.....21
 - Receiving21
 - Unpacking21
 - Inspecting21
 - Set-Up.....21
 - Storing21

SECTION 5—PACKAGING, HANDLING AND SET-UP 22

- Receiving.....22
- Unpacking.....22
 - Unpacking Bed Ends22
 - Unpacking Foot and Head Sections23
- Inspecting.....24
- Set-Up24
 - Assembling/Disassembling Head and Foot Sections24
 - Installing/Removing Universal Bed Ends.....26
 - Installing Casters26
 - Connecting Head Actuator Jumper Cable.....28
 - Assembling/Installing/Removing Drive Shaft30
 - Inspecting the Bed.....32
- Storing the Beds.....32

SECTION 6—MAINTENANCE 33

- Washing Bed Ends.....33
- Cleaning Head and Foot Sections33
- Maintenance Checklist.....34
 - Mechanical Inspection and Maintenance34
 - Electrical Inspection and Maintenance34
 - Pass/Fail34

SECTION 7—TROUBLESHOOTING 35

- Troubleshooting: Electrical.....35
- Troubleshooting: Mechanical36

TABLE OF CONTENTS

APPENDIX 37

 A Guide to Bed Safety Bed Rails in Hospitals, Nursing Homes and Home Health Care: The Facts.....37

 Bed Rail Entrapment Statistics37

 Patient Safety.....37

 The Benefits and Risks of Bed Rails37

 Meeting Patients' Needs for Safety38

 Which Ways of Reducing Risks are Best?38

 Patient or Family Concerns About Bed Rail Use39

 Developed by the Hospital Bed Safety Workgroup39

LIMITED WARRANTY 40

REGISTER YOUR PRODUCT

The benefits of registering include:

1. Safeguarding your investment.
2. Ensuring long-term maintenance and servicing of your product.
3. Receiving updates with product information, maintenance tips and industry news.

Register ONLINE at warranty.invacare.com

Please have your model number and purchase date available to complete your registration.

Any registration information you submit will only be used by Invacare Corporation and protected as required by applicable laws and regulations.

SPECIAL NOTES

Signal words are used in this manual and apply to hazards or unsafe practices which could result in personal injury or property damage. Refer to the table below for definitions of the signal words.

SIGNAL WORD	MEANING
DANGER	Danger indicates an imminently hazardous situation which, if not avoided, will result in death or serious injury.
WARNING	Warning indicates a potentially hazardous situation which, if not avoided, could result in death or serious injury.
CAUTION	Caution indicates a potentially hazardous situation which, if not avoided, may result in property damage.

NOTICE

THE INFORMATION CONTAINED IN THIS DOCUMENT IS SUBJECT TO CHANGE WITHOUT NOTICE.

PENDANT OPERATION

A safety feature of this product includes protection against overheating caused by excessive or extended periods of operation. Depending on the duration, this includes multiple or repeated adjustments or the use of multiple functions at one time. To ensure trouble free operation, **ALWAYS** allow a slight pause between multiple adjustments and avoid pressing more than one function button at a time. If thermal protection activation should occur, the bed will not respond to pendant commands. Given this situation, release the pendant button and allow the bed unit to sit for several minutes. This will allow the protection function time to reset and restore bed function. Depending on severity of the initial overheating, this could take up to 30 minutes.

The emergency crank **MUST** be removed before the bed is used. Failure to remove the crank may cause damage or personal injury.

TYPICAL PRODUCT PARAMETERS

IVC BARIATRIC BED	
FOOT END	
MINIMUM:	26.25 inches (66.7 cm)
MAXIMUM:	33.75 inches (85.7 cm)
DECK HEIGHT*	
MINIMUM (DOWN POSITION):	14 inches (35 cm) ± 2 inches
MAXIMUM (UP POSITION):	22 inches (55 cm) ± 2 inches
BED	
OVERALL LENGTH:	88 inches (223.5 cm)
WIDTH:	42 inches (106.7 cm)
SPLIT SPRINGS TO ENDS	
HEAD:	43 inches (109.2 cm)
FOOT:	45 inches (114.3 cm)
SHIPPING WEIGHT	275 lbs
WEIGHT LIMITATION	700 lbs (Including accessories, mattress, occupant and any other objects positioned on the bed)
<i>*NOTE: Height from floor to bed deck.</i>	

The following table lists each bed model number and the components associated with it. An "X" will denote the components required for a complete bed assembly.

BED NAME (MODEL NUMBER)	BAR600IVC
HEAD SPRING WITH ONE (1) MOTOR (BAR5000IVC)	X
UNIVERSAL BED ENDS (BAR5301IVC)	X
FOOT SPRING WITH TWO (2) MOTORS (BAR5490IVC)	X

LABEL LOCATIONS

NOTE: Underside of bed shown.

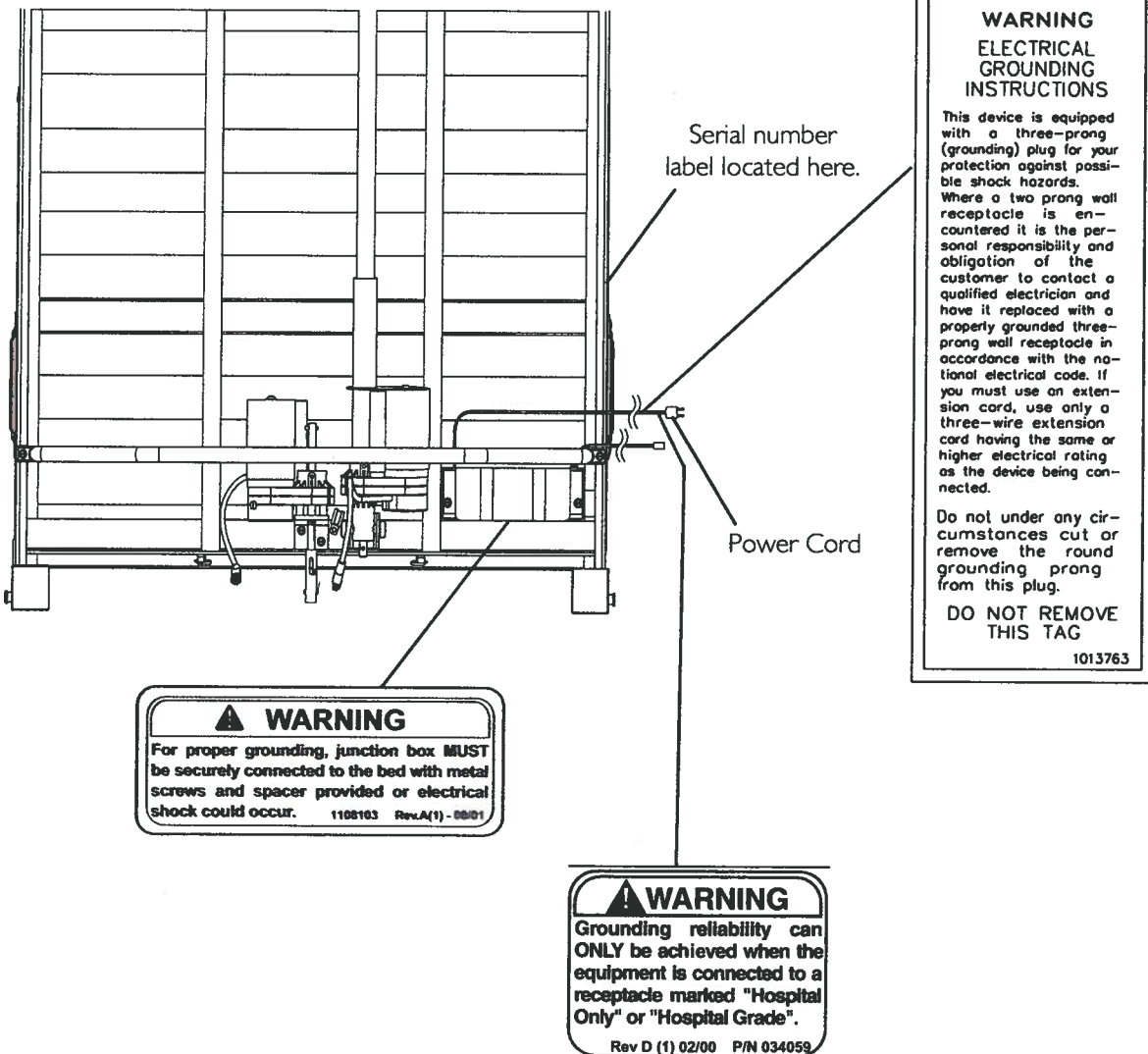

NOTE: Labels located on bed frame.

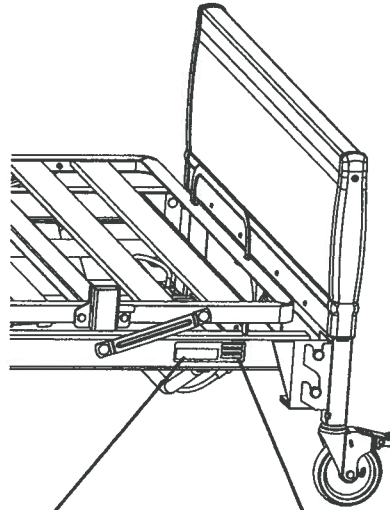

⚠ WARNING
The weight limit of the occupant of the Bariatric Bed **CANNOT** exceed 600 pounds. The **TOTAL** weight limit of the Bariatric Bed (including accessories, mattress, occupant and **ANY** other person/object positioned on the bed) cannot exceed 700 pounds.
Rev. B (1)-01/04 P/N 1098343

⚠ WARNING
The Bariatric Bed is **NOT** designed to be used as a patient transport. When transporting a patient, use an approved patient transport. Otherwise, injury or damage may result.
Rev. B (1)-01/04 P/N 1098347

SECTION I—GENERAL GUIDELINES

⚠ WARNING

SECTION I - GENERAL GUIDELINES contains important information for the safe operation and use of this product.

Important Safety Instructions

When using the bed, basic precautions should always be followed, including the following:

Read all the instructions before using the bed.

DANGER - To reduce the risk of electric shock:

1. Always unplug the bed from the electrical outlet before cleaning.

WARNING - To reduce the risk of burns, fire, electric shock, or injury to persons:

1. Unplug from the outlet before servicing.
2. Close supervision is necessary when the bed is used by, or near children and/or disabled persons.
3. Use this bed only for its intended use as described in these instructions. **DO NOT** use attachments not recommended by the manufacturer.
4. **NEVER** operate this bed if it has a damaged cord or plug, if it is not working properly, if it has been dropped, damaged, or dropped into water. Return the bed to a service center for examination and repair.
5. Keep the cord away from heated surfaces.
6. **DO NOT** use outdoors.
7. Use masked or nasal type oxygen administering equipment only in conjunction with the manual/electric bed. The use of **ANY** other type of oxygen administering equipment can result in a fire hazard.
8. To disconnect, **DO NOT** depress pendant buttons.
9. Risk of electric shock - Connect this bed to a properly grounded outlet only. Refer to Grounding Instructions on page 14.
10. Risk of injury to persons - **DO NOT** place video equipment such as televisions or computer monitors on bed.

SAVE THESE INSTRUCTIONS

Operating Information

Check all parts for shipping damage and test before using. In case of damage, **DO NOT** use. Contact a qualified technician for further instruction.

After any adjustments, repair or service and before use, make sure all attaching hardware is tightened securely.

Close supervision is necessary when the manual/electric bed is used by or near children and physically challenged individuals.

DO NOT let any individual underneath the bed or in between the raised bed frame components at anytime.

When bed is not to be used for an extended period, unplug electric bed from the wall outlet.

Keep the product a minimum of 12 inches away from any direct heat source.

DO NOT unplug power cord from junction box.

If a liquid is spilled in or around the electric bed, unplug the electric bed before cleaning. Clean up the spill and allow the electric bed or the area around the electric bed to dry thoroughly before using the electric controls again.

The manual/electric bed is not designed to be used as a patient transport. When transporting a patient, use an approved patient transport. Otherwise, injury or damage may result.

When operating/moving electric beds, ALWAYS ensure that the individual utilizing the bed is positioned properly within the confines of the bed. DO NOT let any extremities protrude over the side or between the bed rails when performing these functions.

After the electric bed has been assembled, ALWAYS test to make sure that all sections of the electric bed are properly and securely in place before using.

Make sure head and foot springs/sections are connected securely to the universal bed ends before use.

The pendant and power cords MUST be routed and secured properly to ensure that the cords DO NOT become entangled, pinched and/or severed during operation of the electric bed.

NEVER operate the unit if these cords are damaged.

If the unit is not working properly, call a qualified technician to examine the unit and repair it.

Keep all moving parts, including the main frame, mattress deck (head and foot springs/sections) and all drive shafts, free of obstruction (i.e. blankets/sheets, heating blankets/pads, tubing, wiring, etc. and other types of products using electric cords which may get tangled around the bed, side rails or legs) during operation of the electric bed.

The electric bed is equipped with locking casters. When transferring into or out of the electric bed, ALWAYS lock the locking caster(s). Inspect the wheel locks for correct locking action before actual use. Even with casters properly locked, some flooring surfaces such as tile or wood, will allow the bed to move under some conditions. Use on surfaces such as these must be evaluated by the care provider.

⚠ ENTRAPMENT WARNING

Proper patient assessment and monitoring, and proper maintenance and use of equipment is required to reduce the risk of entrapment. Variations in bed rail dimensions, and mattress thickness, size or density could increase the risk of entrapment. Visit the FDA website at <http://www.fda.gov> to learn about the risks of entrapment. Review “A Guide to Bed Safety”, published by the Hospital Bed Safety Workgroup, located at www.invacare.com. Use the link located under each bed rail product entry to access this bed safety guide.

Refer to the owners manuals for beds and rails for additional product and safety information.

After any adjustments, repair or service and before use, make sure all attaching hardware is tightened securely. Assist rails with dimensions different from the original equipment supplied or specified by the bed manufacturer may not be interchangeable and may result in entrapment or other injury.

Mattress MUST fit bed frame and assist rails snugly to reduce the risk of entrapment.

Replacement Parts/Accessories

Use masked or nasal type oxygen administering equipment only in conjunction with the manual/electric bed. The use of any other type of oxygen administering equipment can result in a fire hazard.

When using nasal or masked type oxygen administering equipment, the oxygen or air tubing **MUST** be routed and secured properly to ensure that the tubing does not become entangled and/or severed during normal operation of manual/electric bed.

ALWAYS test to make sure that the side rails are properly and securely in place before using the manual/electric bed.

Invacare recommends that the mattress be centered on the bed frame. Otherwise, individuals may become entangled between the bed rail and the bed frame.

Physically challenged individuals who cannot prevent themselves from rolling/climbing out of the manual/electric bed may require alternative safe means of restraint.

When used with a manual/electric bed, the bed rails **DO NOT** fall under any weight limitations. Bed rails can be deformed or broken if excessive side pressure is exerted on the bed rails. These bed rails are used for the purpose of preventing an individual from inadvertently rolling out of bed. The bed rails are not intended nor may be used for restraint purposes. If an individual is capable of injuring himself/herself, a physician or a healthcare professional should be consulted for alternative means of safe restraint.

After raising/lowering the head/foot end of the electric bed, check the distance between the bottom of the bed rail and the mattress. If there is excessive distance between the bottom of the bed rail and the mattress in which individuals may become entangled, adjust the height of the bed rail (if applicable), or provide alternative means of patient protection.

DO NOT use the side rails as push handles for moving the electric bed.

Replacement mattresses and bed side rails with dimensions different from the original equipment supplied or specified by the bed frame manufacturer are not interchangeable. Variations in bed side rail design, width and thickness or firmness of the mattress could cause/contribute to entrapment.

Electrical

⚠ DANGER

When using an extension cord, use only a three wire extension cord having at least 16 AWG (American Wire Gauge) wire and the same or higher electrical rating as the device being connected. Use of improper extension cord could result in a risk of fire and electric shock. Three prong to two prong adapters should not be used. Use of three prong adapters can result in improper grounding and present a shock hazard to the user.

NEVER operate if the unit has a damaged cord or plug. If it is not working properly, call a qualified technician for examination and repair.

Keep all electrical cords away from heated or hot surfaces.

Ensure all cables and cords are routed such that they will not become entangled or pinched. Otherwise damage or injury may result.

Repair or Service Information

DO NOT open assemblies such as the motors, pendant, junction boxes or gear boxes. No user serviceable parts are inside. Only qualified technicians are permitted to repair these parts. If unqualified individuals perform any work on these beds, the warranty is void.

Unplug the power cord from its power source before performing any maintenance on the electric bed. DO NOT unplug the power cord from the junction box. Damage to cord will result.

Before installing the connector into the junction box, be sure the side with the locking tab is facing downward - otherwise, injury or damage may occur.

Grounding Instructions

Electric beds are equipped with three-prong (grounding) plugs for protection against possible shock hazards. Where a two-prong wall receptacle is encountered, it is the personal responsibility and obligation of the customer to contact a qualified electrician and have the two-prong receptacle replaced with a properly grounded three-prong wall receptacle in accordance with the National Electrical Code. If you must use an extension cord, use only a three-wire extension cord having the same or higher electrical rating as the device being connected. **DO NOT**, under any circumstances, cut or remove the round grounding prong from any plug used with or for Invacare products. In addition, Invacare has placed RED warning tags on some equipment. **DO NOT** remove these tags.

For proper grounding, junction box **MUST** be securely connected to the bed with metal screws and the spacer provided or electrical shock could occur.

Radio Frequency Interference

Electronic equipment may be influenced by Radio Frequency Interference (RFI). Caution should be exercised with regard to the use of portable communications equipment in the area around such equipment. If RFI causes erratic behavior, unplug the electric bed immediately. Leave unplugged while transmission is in progress.

Weight Limitations

The total weight limit of the Bariatric Bed (including accessories, mattress, occupant and any other objects positioned on the bed) is 700 pounds (318 kg); 600 pounds (272 kg) patient weight.

NEVER permit more than one person on the manual/electric bed at any time.

Body weight should be evenly distributed over the surface of the manual/electric bed. **DO NOT** lay, sit or lean in such a way that your entire body weight is placed only on raised head or foot sections of the bed. This includes when repositioning or transferring in or out of bed.

SECTION 2—OPERATION AND ADJUSTMENT

Operating Bariatric Bed

⚠ WARNING

NEVER operate if the unit has a damaged cord or plug. If it is not working properly, call a qualified technician for examination and repair.

Keep all electrical cords away from heated or hot surfaces.

Ensure all cables and cords are routed such that they will not become entangled or pinched. Otherwise, damage or injury may result.

DO NOT place pendant under or between objects. This may unintentionally press the buttons and may cause injury or damage to occur.

Operating Bariatric Bed

NOTE: For this procedure, refer to FIGURE 2.1.

Before placing the bed into use, test it by operating it through all phases of its operation.

1. If any problems arise during the test, recheck all electrical connections and mechanical hook ups.
2. A six-function pendant is used for all bed operations.
3. An emergency crank allows operation in the event of a power outage.

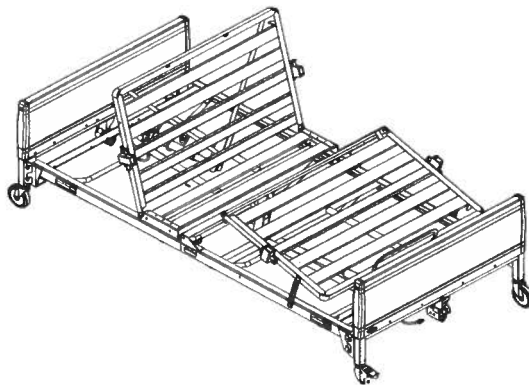

FIGURE 2.1 Operating Bariatric Bed

Raising and Lowering Entire Bed

NOTE: For this procedure, refer to FIGURE 2.2.

1. To raise the entire bed, press the Bed UP button.
2. To lower entire bed, press the Bed DOWN button.

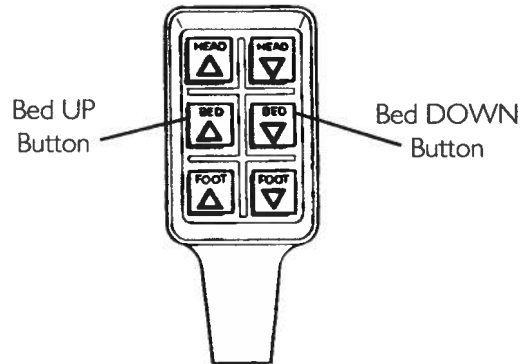

FIGURE 2.2 Raising and Lowering Entire Bed

Raising and Lowering Head and Foot Sections

NOTE: For this procedure, refer to FIGURE 2.3.

1. To raise the head of the bed, press the Head UP button.
2. To lower the head of the bed, press the Head DOWN button.
3. To raise the foot of the bed, press the Foot UP button.
4. To lower the foot of the bed, press the Foot DOWN button.

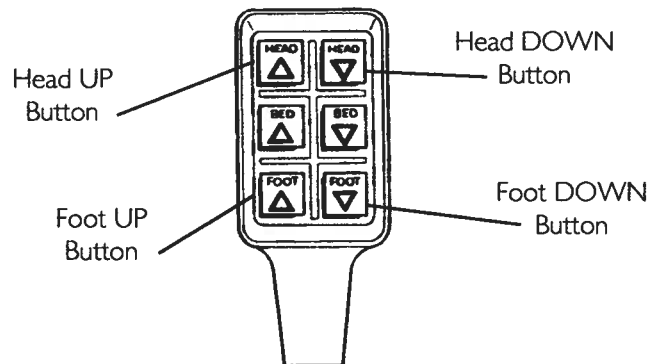

FIGURE 2.3 Raising and Lowering Head and Foot Sections

Emergency Crank

NOTE: For this procedure, refer to FIGURE 2.4.

NOTE: If the bariatric bed must be adjusted manually due to a power outage or an electronic malfunction, use the emergency crank to make the adjustments.

1. Under the bed, locate the exposed shaft end according to the function you want to perform.
2. Attach the emergency crank to the motor shaft end of the head section or the motor shaft end of the foot section.
3. Crank clockwise or counterclockwise to adjust the bed.

NOTE: Push in the emergency crank while turning it the desired direction.

4. Remove the emergency crank.

⚠ WARNING

The emergency crank MUST be removed before the bed is used. Failure to remove the crank may cause damage or personal injury.

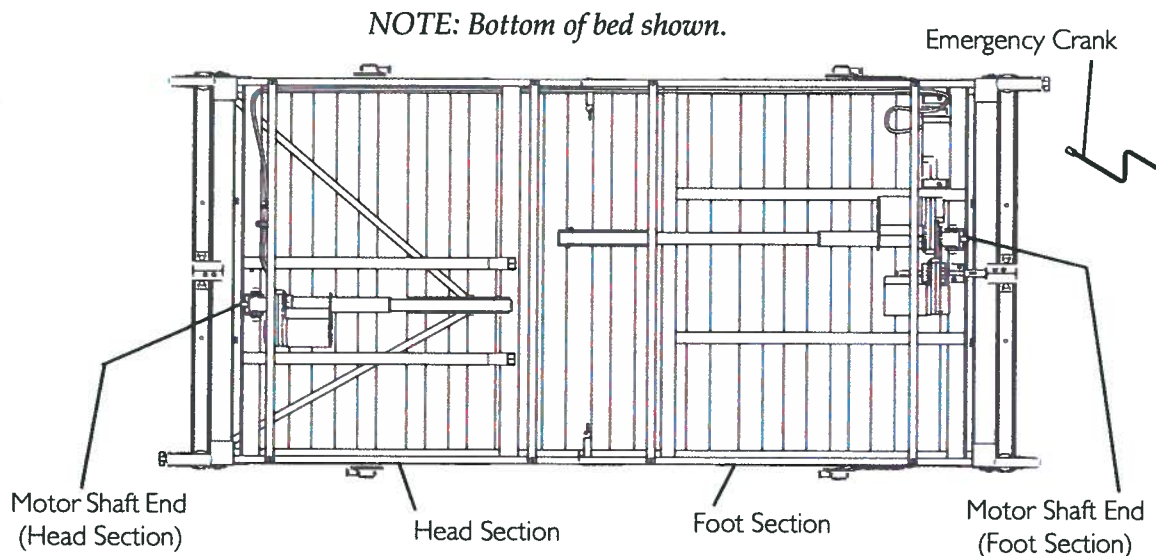

FIGURE 2.4 Emergency Crank

Optional Bed Rails

⚠ WARNING

DO NOT install the optional bed rails without reading and understanding all of the instructions in the instruction sheet that accompanies the bed rail kit.

SECTION 3—MAINTENANCE

Washing Bed Ends

CAUTION

DO NOT wash head or foot section. AC motors and electronics are not water proof.

To protect flooring, ensure bed ends are completely drained and dry before placing on flooring. Otherwise, remaining dirty water may damage or stain flooring.

Avoid spraying water directly into the gear box ends. Otherwise, damage to the gear box may occur.

NOTE: For this procedure, refer to FIGURE 3.1.

1. Stand or prop each bed end in an upright position on its legs.
2. Using a mild soap/detergent and soft bristle brush or sponge, scrub all exterior surfaces.
3. Using a hose and nozzle attachment, rinse bed ends thoroughly with plain cold or warm water.

NOTE: DO NOT exceed a water temperature of 110° F.

NOTE: Use household tap pressure. DO NOT use pressure washers or steam cleaners.

4. Tip bed end from side to side to allow any collected or trapped water to drain.
5. Thoroughly towel dry bed end and all components.
6. Repeat drying process until all components are dry.

NOTE: Ensure that the bed end is completely dry before storing.

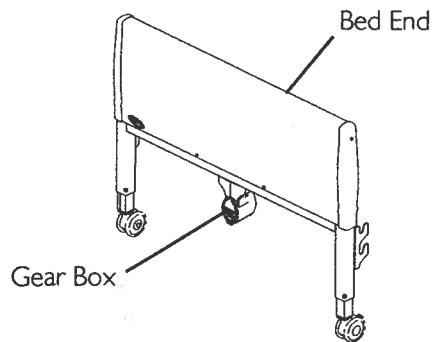

FIGURE 3.1 Washing Bed Ends

Cleaning Head and Foot Sections

1. Unplug the power cord of electric beds before performing maintenance.
2. Wipe down the bed with disinfectant. Allow it to dry completely.

Maintenance and Cleaning Checklist

Invacare recommends the following maintenance and cleaning procedures be conducted between uses and at least once every three years. This form is provided as a guide to help with documentation.

Cleaning and Disinfecting Bed

- Unplug the power cord of electric beds before performing maintenance.
- Wipe down with disinfectant. Allow to dry completely.

Mechanical Inspection and Maintenance

- Inspect all bed components for damage or excessive wear.
- Visually examine all welds for cracks.
- Inspect the head and foot spring sections for bending, warping or damage.
- Check drive shaft and drive shaft connections for bending, damage or excessive wear.
- Inspect pull tubes and mounting hardware for bending, damage or excessive wear.
- Inspect all bolts and rivets to ensure that they are securely tightened and functioning properly.
- Check sleep surfaces to ensure all links are intact.
- Check casters to ensure they lock, if applicable, and roll properly.

Electrical Inspection and Maintenance

- Inspect all electrical bed components for damage or excessive wear (i.e., cracked or broken housings, or worn components).
- Check pendant, power and motor cords for chafing, cuts or excessive wear.
- Make sure all plugs are fully attached and free of damage.
- Check all functions:
 - A. Head raises and lowers properly.
 - B. Foot raises and lowers properly.
 - C. Bed ends raise and lower properly.

PASS/FAIL

- PASS: Bed and all components have passed all of the preceding inspection criteria, and the bed is ready for placement into a client's home.
- FAIL: Bed, or any component, has failed any of the preceding inspection criteria. Tag the bed or component with a complete description of the failure(s) and have the bed serviced.

SECTION 4—TROUBLESHOOTING

⚠ WARNING

Read all general guidelines, warnings and cautions before performing any repair/maintenance on the bed. All repair and maintenance on the bed should be performed by a qualified technician.

Troubleshooting: Electrical

SYMPTOM	PROBABLE CAUSE	SOLUTIONS
Bed section does not move.	End of stroke reached.	Operate opposite button.
Full Electric Bed: Hi/Lo function does not work.	Bed not plugged in.	Ensure power cord is plugged into power source.
	Pendant not functioning.	Ensure Pendant correctly connected to junction box. Ensure Pendant cable is not entangled/pinched.
	Cables	Ensure cables are not entangled/pinched. Call the dealer for repair/replacement of cables and/or motors.
	Household fuse or breaker blown.	Check household fuse/breaker box.
	Motors are not functioning.	Call dealer.
	Hi/Lo Motor	Ensure cables are not entangled or pinched. Ensure drive shaft is correctly installed.
Bed Spring does not stop moving.	Pendant	Check for depressed/stuck buttons. If button is stuck, call dealer for repair.
Bed Hi/Lo movement does not stop.		Check cables. If damaged, call dealer.

Troubleshooting: Mechanical

SYMPTOM	PROBABLE CAUSE	SOLUTIONS
Bed does not stay in place.	Locking casters not locked.	Lock casters.
Bed sections do not move.	Pull tube	Check pull tube(s) for binding. Call dealer for repairs.
Bed ends move in opposite directions (electrical or manual bed).	Drive shaft connected to wrong gear box shaft.	Call dealer.
Hi/Lo function does not work.	Drive shaft disconnected.	Call dealer.
Pressing function on pendant results in motion other than that intended.	Motor cable connections to junction box incorrect.	Call dealer.

ASSEMBLY, MAINTENANCE AND ADJUSTMENT SECTIONS - FOR DEALERS ONLY

⚠ WARNING

The procedures in the following sections **MUST** be performed by a qualified technician.

Overview of Procedures

Receiving

Unpacking

- Unpacking the Bed Ends
- Unpacking Foot and Head Spring Sections

Inspecting

Set-Up

- Assembling and Disassembling the Head and Foot Spring Sections
- Installing/Removing Universal Bed Ends
- Installing Casters
- Connecting Head Actuator Jumper Cable
- Assembling/Installing/Removing the Drive Shaft
- Inspecting the Bed

Storing

SECTION 5—PACKAGING, HANDLING AND SET-UP

Receiving

1. Count cartons before signing shipping papers.
2. Designate someone at the facility to receive and inspect all merchandise. Use the master order acknowledgment to check off items as they are received.
3. Compare the number of cartons shipped with the number of cartons actually received and note such on the consignee copy of the freight bill. Make sure to have the truck driver sign the copy acknowledging the count.
4. If shortage occurs, IMMEDIATELY contact Invacare Customer Service department at (800) 333-6900.

Unpacking

The bed is contained in three cartons.

1. Check bed components for any obvious damage to the carton or its contents. If damage is evident, contact your local Invacare dealer.
2. Remove any loose packing from the cartons.
3. Carefully remove all components from the cartons.

⚠ WARNING

DO NOT plug the power cord into a power source until assembly is complete. To do so could result in damage or personal injury.

DO NOT attempt to operate bed controls prior to completion of assembly. Otherwise, damage to bed components may occur.

Unpacking Bed Ends

NOTE: For this procedure, refer to FIGURE 5.1 on page 23.

1. The bed end carton includes:
 - Two universal bed ends.
 - Four casters (two locking and two non-locking casters).
 - One drive shaft assembly in two pieces.

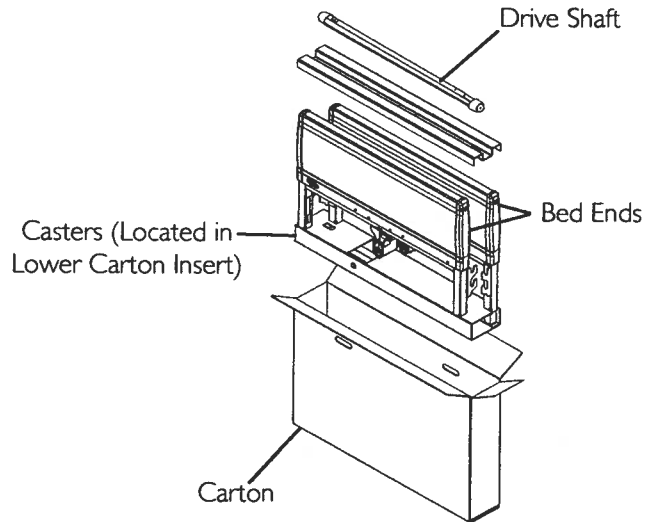
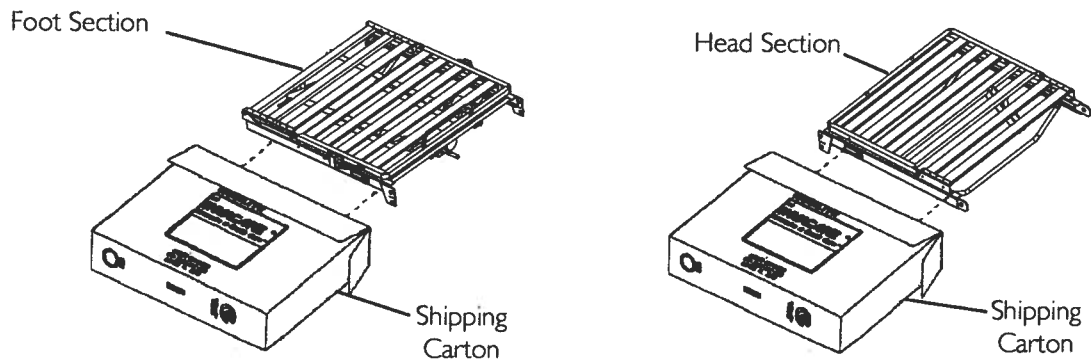

FIGURE 5.1 Unpacking Bed Ends

Unpacking Foot and Head Sections

NOTE: For this procedure, refer to FIGURE 5.2.

1. The foot section carton includes:
 - One foot section (including pendant, junction box with power cord and foot and hi/lo motors with cables).
 - One emergency crank handle.
2. The head section carton includes:
 - One head section.



NOTE: Not shown - Packing inserts, junction box with cord, motors with cables attached, pendant, emergency crank handle, and owner's manual.

FIGURE 5.2 Unpacking Foot and Head Sections

Inspecting

Examine each item carefully for scratches, nicks, dents or any other apparent damage.

NOTE: Check all parts for shipping damage. In case of shipping damage, DO NOT use. Contact Dealer/Carrier for further instruction.

1. Inspect the power supply cord and cables for cuts or damage to the cord and/or plug.
2. Inspect the junction box for any damage to the connectors.
3. Ensure that the motor plugs are plugged into the junction box and fit properly.

Set-Up

Assembling/Disassembling Head and Foot Sections

⚠ WARNING

DO NOT attempt to operate bed controls prior to completion of assembly as damage to bed components or personal injury may occur.

NOTE: For this procedure, refer to FIGURE 5.3 on page 25.

Assembling

1. Remove the head section of the bed from the packing carton.

NOTE: Place the head section on a flat surface so that the motor guards on the bottom of the frame are supporting the head section.

2. Remove the foot section of the bed from the packing carton.
3. Remove tie-wraps securing the cables for shipping.

NOTE: Place the foot section on a flat surface so that the motor guards on the bottom of the frame are supporting the foot section.

4. Align the inside of the head section with the inside of the foot section.

NOTE: Locking pins are located on the foot section frame and will make an audible click when properly engaged with the head section frame.

5. Push the head section towards the foot section so that the head section frame slides into the foot section frame and the locking pins engage.
6. Ensure the locking pins are properly engaged by attempting to pull the head section from the foot section. If the sections separate, repeat STEP 6-7 until the locking pins are secure.
7. Install the universal bed ends. Refer to Installing/Removing Universal Bed Ends on page 26.
8. Connect the head actuator jumper cable. Refer to Connecting Head Actuator Jumper Cable on page 28.

9. Assemble and install the drive shaft. Refer to Assembling/Installing/Removing Drive Shaft on page 30.
10. Activate the bed functions. Refer to Inspecting the Bed on page 32.

Disassembling

1. Lower the head and foot sections completely. Refer to Raising and Lowering Head and Foot Sections on page 16.
2. Lower the bed to the lowest height. Refer to Raising and Lowering Entire Bed on page 16.
3. Remove the drive shaft. Refer to Assembling/Installing/Removing Drive Shaft on page 30.
4. Disconnect the head actuator jumper cable.
5. Remove both universal bed ends. Refer to Installing/Removing Universal Bed Ends on page 26.

NOTE: Place the bed on a flat surface so that the motor guards on the bottom of the frame are supporting the bed.

6. Starting with one side of bed, pull the release pin and pull the head section so that it starts to separate slightly from the foot section.
7. On the opposite side of bed, pull the release pin.
8. Separate the head section from the foot section.

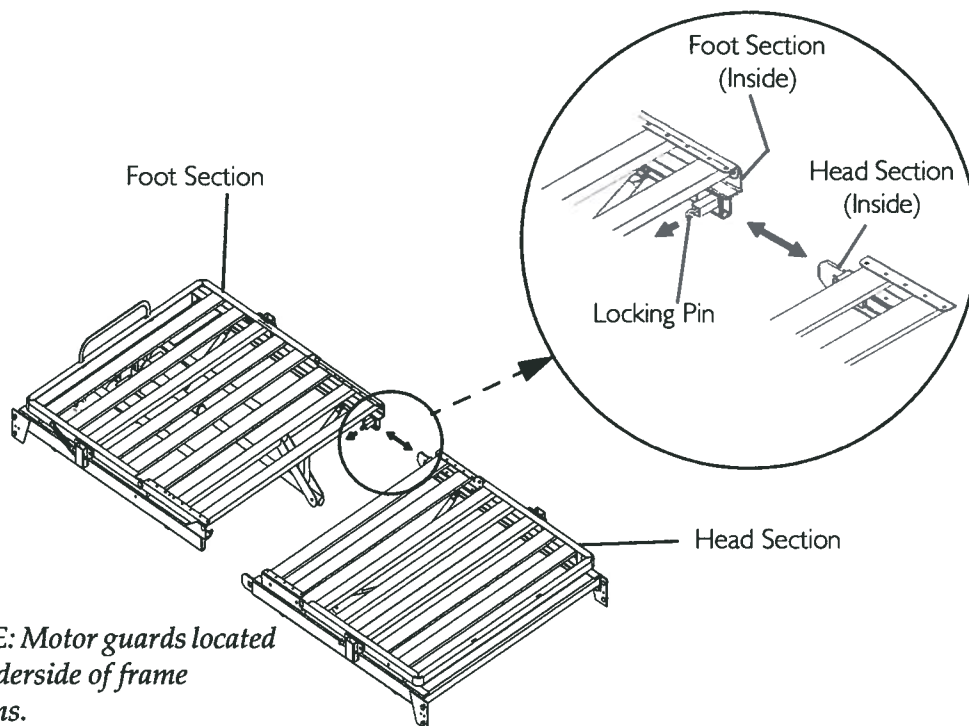

NOTE: Motor guards located on underside of frame sections.

FIGURE 5.3 Assembling/Disassembling Head and Foot Sections

Installing/Removing Universal Bed Ends

⚠ WARNING

DO NOT place your hand between the head section and the universal bed end while assembling. Otherwise, injury may occur.

NOTE: For this procedure, refer to FIGURE 5.4.

NOTE: Reverse this procedure to remove the universal bed ends.

1. Stand one bed end as close to the head section as possible.
2. With one hand, grasp the head section and raise it until the corner plate head rivets of the section are high enough to place into the corner locks on the bed end.
3. Tilt the bed end toward the head section and place the corner plate head rivets into the corner locks.
4. Return the universal bed end to its full upright position. The corner plate head rivets will lock into place.
5. Repeat STEPS 1-4 to install the remaining bed end to the foot spring section.
6. If necessary, install the casters. Refer to [Installing Casters](#) on page 26.

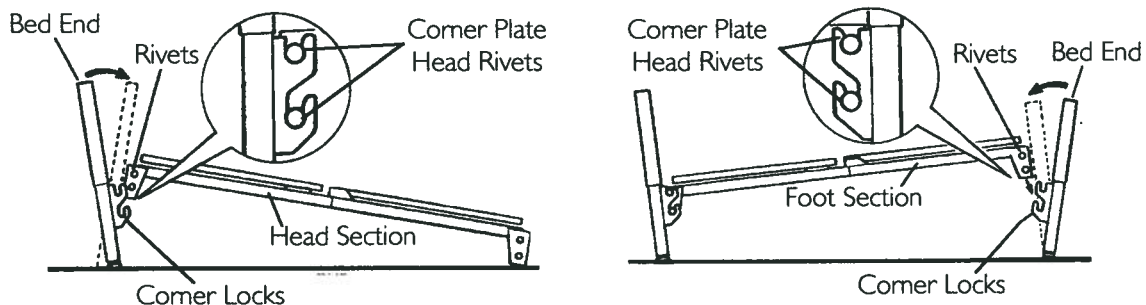

FIGURE 5.4 Installing/Removing Universal Bed Ends

Installing Casters

⚠ WARNING

Ensure that the locking casters are installed diagonally from each other and are locked. Otherwise, damage or personal injury could occur.

The proper casters are provided with the Bariatric Bed. **DO NOT** use any other casters with the Bariatric Bed. Otherwise, damage or personal injury could occur.

Ensure that casters are locked and that the bed does not move before transferring. **DO NOT** transfer occupant if bed is not stable.

NOTE: For this procedure, refer to FIGURE 5.5 on page 27.

NOTE: ALWAYS locate locking caster in the same location on each bed end so that they will always be assembled diagonally opposite each other when inventory is mixed.

NOTE: Position the two locking casters so that they will be diagonally opposite from one another when the bed is assembled.

NOTE: If two locking casters are not included with the bed, contact an Invacare dealer.

1. To install casters, lay the bed ends flat on the floor.
2. Insert the caster shaft into the caster socket.
3. To prevent excess movement of the bed during assembly, lock each of the two locking casters by pushing down on the caster lock.

NOTE: Locking the casters may not prevent the bed from moving on slick or slippery surfaces.

4. To unlock each of the two locking casters, push down on the caster lock labeled off.

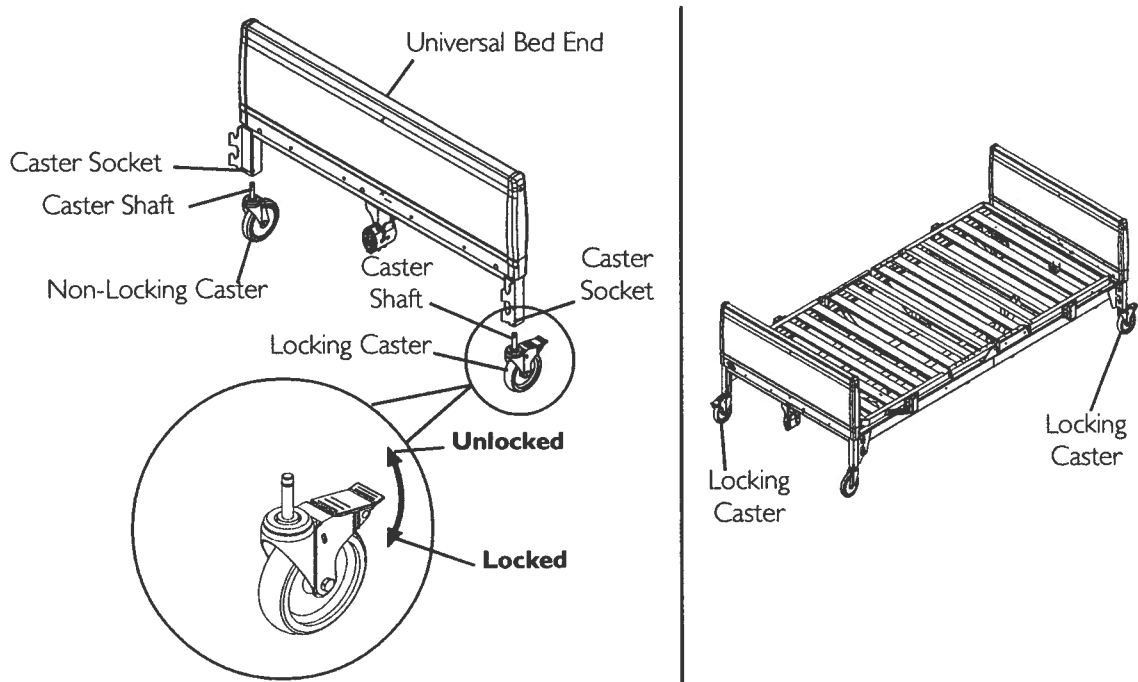

FIGURE 5.5 Installing Casters

Connecting Head Actuator Jumper Cable

⚠ WARNING

Ensure that the head actuator jumper cable does not hang loosely below the side channel. Otherwise, the cable could present a tripping hazard.

NOTE: If the head actuator jumper cable is 43 inches long, refer to Short Head Actuator Jumper Cable on page 28.

NOTE: If the head actuator jumper cable is 84 inches long, refer to Long Head Actuator Jumper Cable on page 28.

NOTE: Reverse this procedure to disconnect the head actuator jumper cable.

Short Head Actuator Jumper Cable

NOTE: For this procedure, refer to Detail "A" of FIGURE 5.6 on page 29.

1. Connect the head actuator jumper cable to the cable from the head actuator.

Long Head Actuator Jumper Cable

NOTE: For this procedure, refer to Detail "B" of FIGURE 5.6 on page 29.

1. Thread the head actuator jumper cable from the junction box through the two loops in the head end.
2. Connect the head actuator jumper cable to the short cable from the head actuator.
3. Gently pull the head actuator jumper cable toward the junction box so that any slack in the cable is taken up near the junction box.

DETAIL "A" - SHORT HEAD ACTUATOR JUMPER CABLE

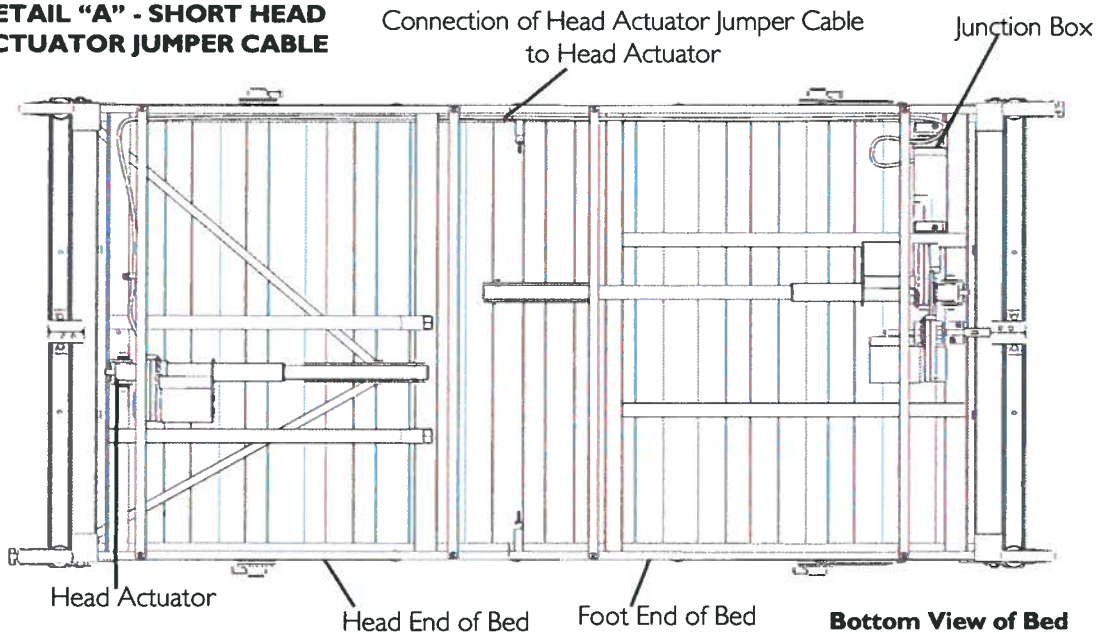

DETAIL "B" - LONG HEAD ACTUATOR JUMPER CABLE

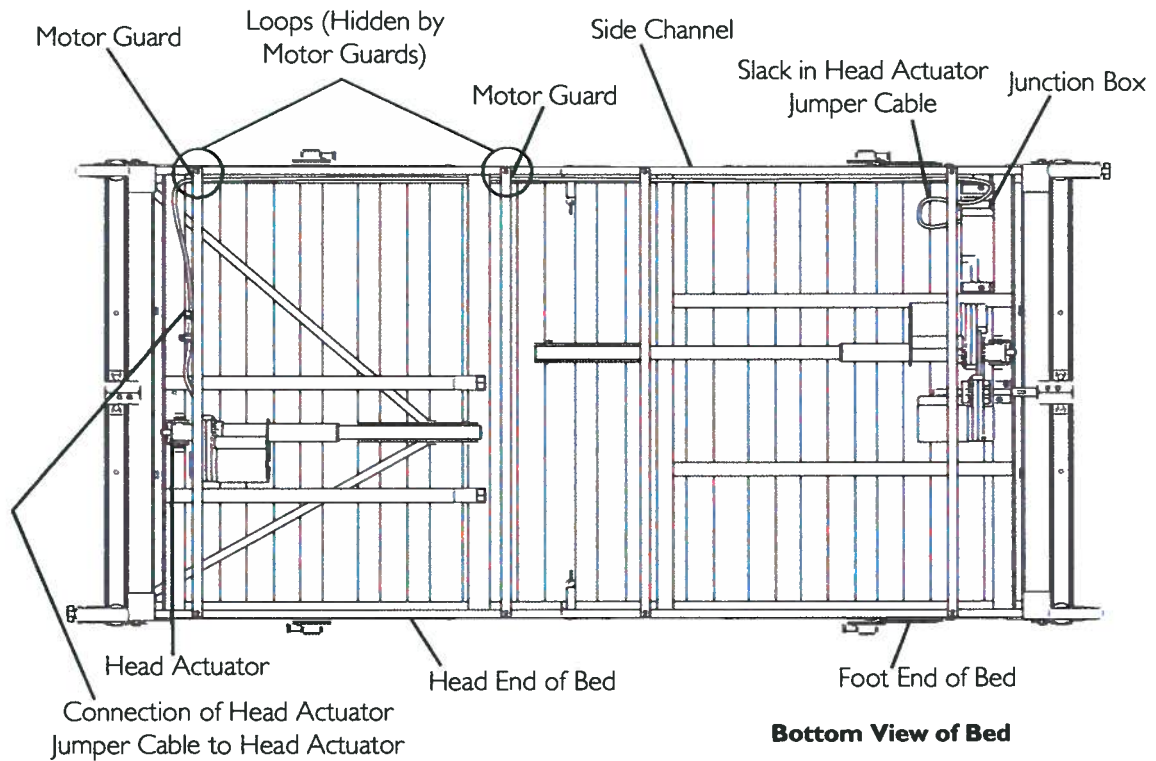

FIGURE 5.6 Connecting Head Actuator Jumper Cable

Assembling/Installing/Removing Drive Shaft

NOTE: For this procedure, refer to FIGURE 5.7 and FIGURE 5.8 on page 31.

NOTE: Reverse this procedure to remove the drive shaft.

NOTE: The drive shaft for the Hi/Lo function consists of two sections that are shipped unassembled. The inner shaft has a positioning spring button, and the outer shaft has three positioning holes, one storage position hole and a telescoping end.

1. Remove the plastic caps from each end of the drive shaft.
2. Press the spring button on the inner shaft and insert the inner shaft into the outer shaft.
3. Engage the spring button into the third positioning hole. Refer to FIGURE 5.7.

NOTE: A common gear box is used on both bed ends. The bottom output shaft is used at the head end and the top output shaft is used at the foot end of the bed.

NOTE: Before assembling the bed ensure the drive shaft cover of both gear boxes are in the correct position: up for the head end and down for the foot end. Refer to FIGURE 5.8.

4. Attach the inner shaft to the bottom gear box output shaft on the head end of the bed.
5. Push in on the spring loaded end of the drive shaft and attach to the Hi/Lo motor output shaft facing the head end of the bed.

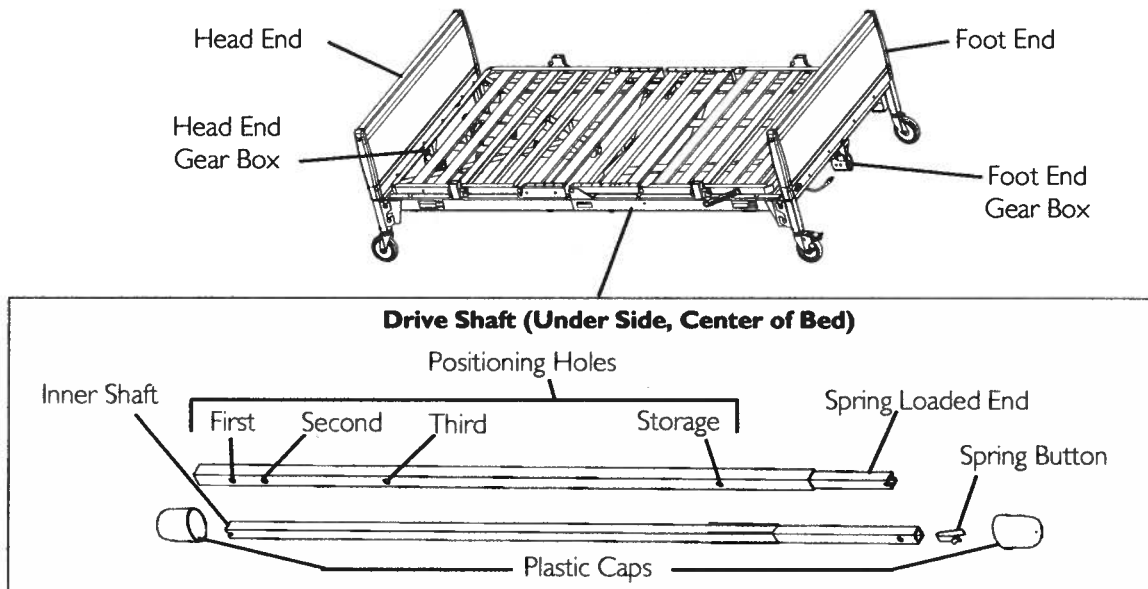

FIGURE 5.7 Assembling/Installing/Removing Drive Shaft

6. Locate the Hi/Lo motor output shaft spring-loaded coupler.

NOTE: If necessary, shift the bed end to the right or left to align the Hi/Lo motor output shaft spring-loaded coupler with the foot end gear box.

7. Ensure the Hi/Lo motor output shaft spring-loaded coupler is properly aligned with the foot end gear box as shown in Detail "A" of FIGURE 5.8.

8. Release the Hi/Lo motor output shaft spring-loaded coupler by pushing in against the Hi/Lo motor output shaft spring-loaded coupler and turning clockwise.

NOTE: The coupling will release and engage the foot end top gear box output shaft cross pins.

9. Ensure that all components are securely installed.

⚠ WARNING

Close the drive shaft covers over all drive shafts that are not in use before placing the bed in service. Otherwise, damage or injury may occur.

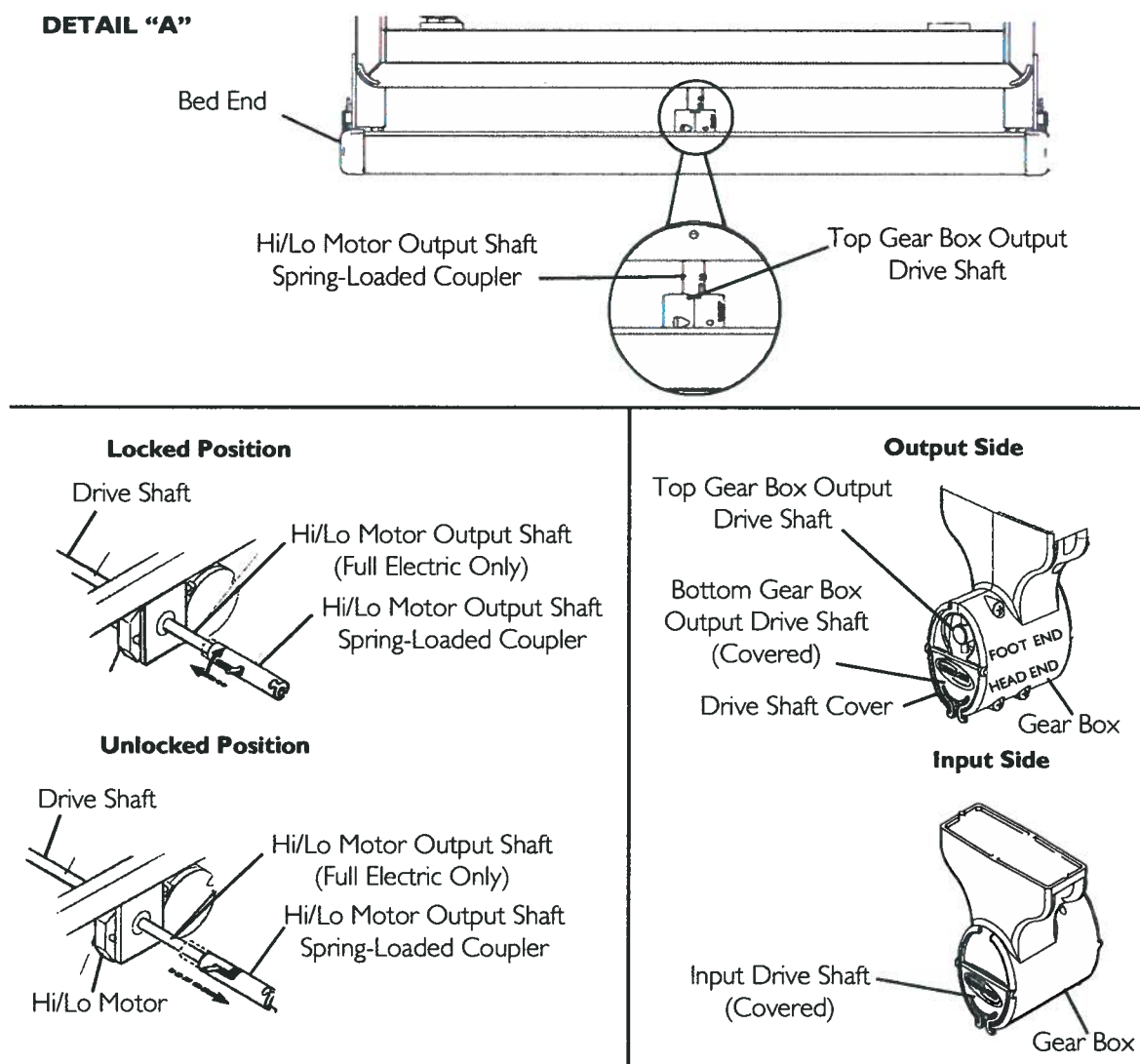

FIGURE 5.8 Assembling/Installing/Removing Drive Shaft

Inspecting the Bed

⚠ WARNING

The removal and installation of cables are to be performed by a qualified technician. All motors, the junction box, connectors and wiring are located on the foot and head sections.

NOTE: For this procedure, refer to FIGURE 5.9.

NOTE: All connectors will arrive plugged into the junction box.

1. Check all electrical connections on junction box at foot end to ensure that all motors are plugged into the correct locations.
2. Plug the junction power box cord into a 110-volt outlet.

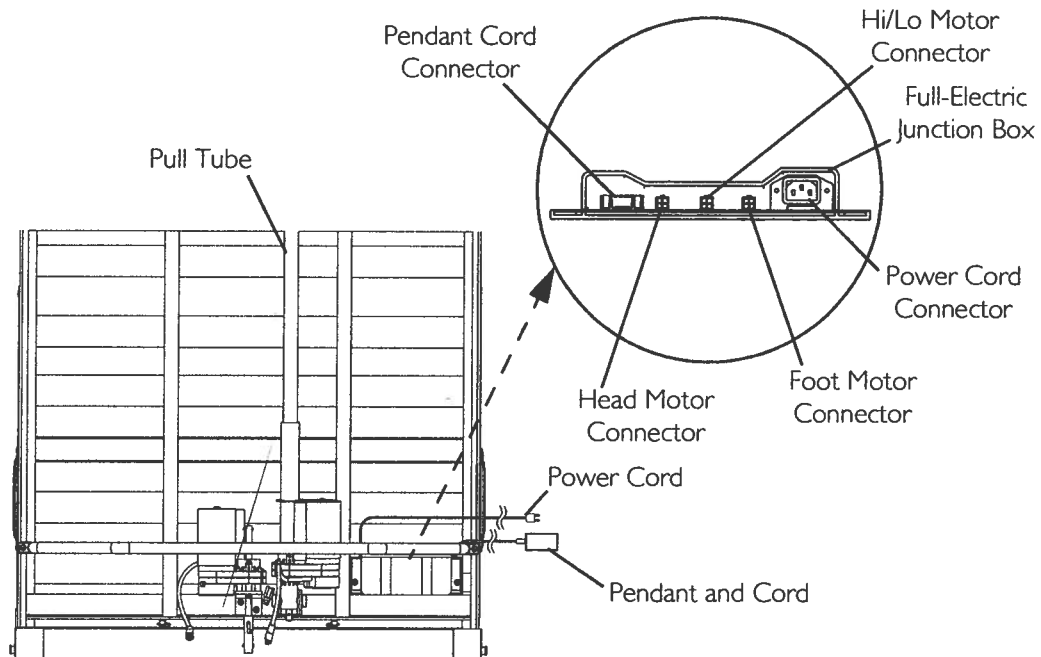

FIGURE 5.9 Inspecting the Bed

Storing the Beds

⚠ WARNING

DO NOT place other objects on top of the cartons.

If bed is not being assembled immediately, retain the cartons and packaging for storage until ready for assembly.

Store the Invacare homecare bed in a dry area.

SECTION 6—MAINTENANCE

Washing Bed Ends

CAUTION

DO NOT wash head or foot section. **AC** motors and electronics are not water proof.

NOTE: For this procedure, refer to FIGURE 6.1.

1. Stand or prop each bed end in an upright position on its legs.
2. Using a mild soap/detergent and soft bristle brush or sponge, scrub all exterior surfaces.
3. Using a hose and nozzle attachment, rinse bed ends thoroughly with plain cold or warm water.

NOTE: DO NOT exceed a water temperature of 110° F.

NOTE: Use household tap pressure. DO NOT use pressure washers or steam cleaners.

CAUTION

To protect flooring, ensure bed ends are completely drained and dry before placing on flooring. Otherwise, remaining dirty water may damage or stain flooring.

Avoid spraying water directly into the gear box ends. Otherwise, damage to the gear box may occur.

4. Tip bed end from side to side to allow any collected or trapped water to drain.
5. Thoroughly towel dry bed end and all components.
6. Repeat drying process until all components are dry.

NOTE: Ensure that the bed end is completely dry before storing.

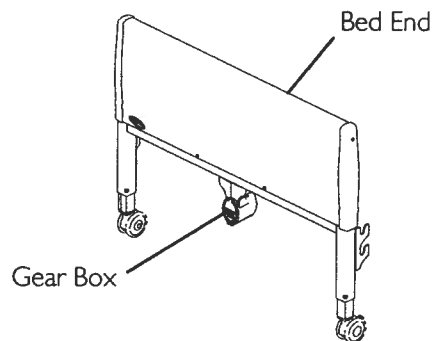

FIGURE 6.1 Washing Bed Ends

Cleaning Head and Foot Sections

1. Unplug the power cord of electric beds before performing maintenance.
2. Wipe down the bed with disinfectant. Allow it to dry completely.

Maintenance Checklist

Invacare recommends the following maintenance and cleaning procedures be conducted between users or as needed. This form is provided as a guide to help with documentation.

Mechanical Inspection and Maintenance

- Inspect all bed components for damage or excessive wear.
- Visually examine all welds for cracks.
- Inspect the head and foot spring sections for bending, warping or damage.
- Check drive shaft and drive shaft connections for bending, damage or excessive wear.
- Inspect pull tubes and mounting hardware for bending, damage or excessive wear.
- Inspect all bolts and rivets to ensure that they are securely tightened and functioning properly.
- Inspect bed ends for proper operation.
 - A. Adjust bed ends to the lowest position.
 - B. Remove universal bed ends from head or foot spring.
 - C. Remove universal bed end caps and plastic cover.
 - D. Inspect cables and pulleys for wear.
 - E. Inspect Acme screws for lubrication. Apply a light lithium based grease if necessary.
 - F. Reinstall the plastic cover and end caps.
- Check casters to ensure they lock, if applicable, and roll properly.

Electrical Inspection and Maintenance

- Inspect all electrical bed components for damage or excessive wear (i.e., cracked or broken housings, or worn components).
- Check pendant, power and motor cords for chafing, cuts or excessive wear.
- Make sure all plugs are fully attached and free of damage.
- Check all functions (head, foot, and bed ends raise and lower properly).

Pass/Fail

- PASS: Bed and all components have passed all of the above inspection criteria and the bed is ready for placement into a client's home.
- FAIL: Bed, or any component, has failed any of the above inspection criteria. Tag the bed or component with a complete description of the failure(s) and have the bed serviced.

SECTION 7—TROUBLESHOOTING

⚠ WARNING

Read all general guidelines, warnings and cautions before performing any repair/maintenance on the bed. All repair and maintenance on the bed should be performed by a qualified technician.

Troubleshooting: Electrical

SYMPTOM	PROBABLE CAUSE	SOLUTIONS
Bed section does not move.	End of stroke reached.	Operate opposite button.
Full Electric Bed: Hi/Lo function does not work.	Bed not plugged in.	Ensure power cord is plugged into power source.
	Pendant not functioning.	Ensure Pendant correctly connected to junction box. Refer to FIGURE 5.9. Ensure Pendant cable is not entangled/pinched.
	Cables	Ensure motor cable(s) correctly connected. Refer to FIGURE 5.9. Ensure cables are not entangled/pinched. Call the dealer for repair/replacement of cables and/or motors.
	Household fuse or breaker blown.	Check household fuse/breaker box.
	Motors are not functioning.	Call dealer.
	Hi/Lo Motor	Ensure Hi/Lo motor cable is correctly connected. Refer to FIGURE 5.9. Ensure cables are not entangled or pinched. Ensure drive shaft is correctly installed.
Bed Spring does not stop moving.	Pendant	Check for depressed/stuck buttons. If button is stuck, call dealer for repair.
Bed Hi/Lo movement does not stop.		Check cables. If damaged, call dealer.

Troubleshooting: Mechanical

SYMPTOM	PROBABLE CAUSE	SOLUTIONS
Bed does not stay in place.	Locking casters not locked.	Lock casters. Refer to <u>Installing Casters</u> on page 26.
Bed sections do not move.	Pull tube	Ensure pull tubes are properly connected. Refer to FIGURE 5.9. Check pull tube(s) for binding. Call dealer for repairs.
Bed ends move in opposite directions (electrical or manual bed).	Drive shaft connected to wrong gear box shaft.	Reinstall drive shaft. Refer to <u>Assembling/Installing/Removing Drive Shaft</u> on page 30.
Hi/Lo function does not work.	Drive shaft disconnected.	Reinstall drive shaft. Refer to <u>Assembling/Installing/Removing Drive Shaft</u> on page 30.
Pressing function on pendant results in motion other than that intended.	Motor cable connections to junction box incorrect.	Verify connections. Refer to FIGURE 5.9.

APPENDIX

SPECIAL NOTE

For your convenience, the March 2006 version of the FDA's bed safety guidelines are provided in this section. The information from the FDA's brochure, published by Hospital Bed Safety Workgroup, is reproduced verbatim, the latest revision of which is available at <http://www.fda.gov>.

A Guide to Bed Safety Bed Rails in Hospitals, Nursing Homes and Home Health Care: The Facts

Bed Rail Entrapment Statistics

Today there are about 2.5 million hospital and nursing home beds in use in the United States. Between 1985 and 2005, 691 incidents of patients* caught, trapped, entangled, or strangled in beds with rails were reported to the U.S. Food and Drug Administration. Of these reports, 413 people died, 120 had a nonfatal injury, and 158 were not injured because staff intervened. Most patients were frail, elderly or confused.

**NOTE: In this brochure, the term patient refers to a resident of a nursing home, any individual receiving services in a home care setting, or patients in hospitals.*

Patient Safety

Patients who have problems with memory, sleeping, incontinence, pain, uncontrolled body movement, or who get out of bed and walk unsafely without assistance, must be carefully assessed for the best ways to keep them from harm, such as falling. Assessment by the patient's health care team will help to determine how best to keep the patient safe. Historically, physical restraints (such as vests, ankle or wrist restraints) were used to try to keep patients safe in health care facilities. In recent years, the health care community has recognized that physically restraining patients can be dangerous. Although not indicated for this use, bed rails are sometimes used as restraints. Regulatory agencies, health care organizations, product manufacturers and advocacy groups encourage hospitals, nursing homes and home care providers to assess patients' needs and to provide safe care without restraints.

The Benefits and Risks of Bed Rails

Potential benefits of bed rails include:

- Aiding in turning and repositioning within the bed.
- Providing a hand-hold for getting into or out of bed.
- Providing a feeling of comfort and security.
- Reducing the risk of patients falling out of bed when being transported.
- Providing easy access to bed controls and personal care items.

Potential risks of bed rails may include:

- Strangling, suffocating, bodily injury or death when patients or part of their body are caught between rails or between the bed rails and mattress.
- More serious injuries from falls when patients climb over rails.
- Skin bruising, cuts, and scrapes.
- Inducing agitated behavior when bed rails are used as a restraint.
- Feeling isolated or unnecessarily restricted.
- Preventing patients, who are able to get out of bed, from performing routine activities such as going to the bathroom or retrieving something from a closet.

Meeting Patients' Needs for Safety

Most patients can be in bed safely without bed rails. Consider the following:

- Use beds that can be raised and lowered close to the floor to accommodate both patient and health care worker needs.
- Keep the bed in the lowest position with wheels locked.
- When the patient is at risk of falling out of bed, place mats next to the bed, as long as this does not create a greater risk of accident.
- Use transfer or mobility aids.
- Monitor patients frequently.
- Anticipate the reasons patients get out of bed such as hunger, thirst, going to the bathroom, restlessness and pain; meet these needs by offering food and fluids, scheduling ample toileting, and providing calming interventions and pain relief.

When bed rails are used, perform an on-going assessment of the patient's physical and mental status; closely monitor high-risk patients. Consider the following:

- Lower one or more sections of the bed rail, such as the foot rail.
- Use a proper size mattress or mattress with raised foam edges to prevent patients from being trapped between the mattress and rail.
- Reduce the gaps between the mattress and side rails.

Which Ways of Reducing Risks are Best?

A process that requires ongoing patient evaluation and monitoring will result in optimizing bed safety. Many patients go through a period of adjustment to become comfortable with new options. Patients and their families should talk to their health care planning team to find out which options are best for them.

Patient or Family Concerns About Bed Rail Use

If patients or family ask about using bed rails, health care providers should:

- Encourage patients or family to talk to their health care planning team to determine whether or not bed rails are indicated.
- Reassure patients and their families that in many cases the patient can sleep safely without bed rails.
- Reassess the need for using bed rails on a frequent, regular basis.

To report an adverse event or medical device problem, please call FDA's MedWatch Reporting Program at 1-800-FDA-1088.

For additional copies of the brochure, see the FDA's website at <http://www.fda.gov/cdrh/beds/>

For more information about this brochure, contact Beryl Goldman at 610-388-5580 or by e-mail at bgoldman@kcorp.kendal.org. She has volunteered to answer questions.

For information regarding a specific hospital bed, contact the bed manufacturer directly.

Developed by the Hospital Bed Safety Workgroup

Participating Organizations:

- AARP
- ABA Tort and Insurance Practice Section
- American Association of Homes and Services for the Aging
- American Health Care Association
- American Medical Directors Association
- American Nurses Association
- American Society for Healthcare Engineering of the American Hospital Association
- American Society for Healthcare Risk Management
- Basic American Metal Products
- Beverly Enterprises, Inc.
- Care Providers of Minnesota
- Carroll Healthcare
- DePaul College of Law
- ECRI
- Evangelical Lutheran Good Samaritan Society
- Hill-Rom Co., Inc.
- Joint Commission on Accreditation of Healthcare Organizations
- Medical Devices Bureau, Health Canada
- National Association for Home Care
- National Citizens' Coalition for Nursing Home Reform
- National Patient Safety Foundation
- RN+ Systems
- Stryker Medical
- Sunrise Medical, Inc.
- The Jewish Home and Hospital
- Untie the Elderly, The Kendal Corporation
- U.S. Food and Drug Administration

Updated March 2006

LIMITED WARRANTY

PLEASE NOTE: THE WARRANTY BELOW HAS BEEN DRAFTED TO COMPLY WITH FEDERAL LAW APPLICABLE TO PRODUCTS MANUFACTURED AFTER JULY 4, 1975.

This warranty is extended only to the original purchaser who purchases this product when new and unused from Invacare or a dealer. This warranty is not extended to any other person or entity and is not transferable or assignable to any subsequent purchaser or owner. Coverage under this warranty will end upon any such subsequent sale or other transfer of title to any other person.

This warranty gives you specific legal rights and you may also have other legal rights which vary from state to state.

Invacare warrants the mechanical and electrical components of this product when purchased new and unused to be free from defects in materials and workmanship for a period of one year from date of purchase from Invacare or a dealer, with a copy of the seller's invoice required for coverage under this warranty. Invacare warrants all welds of this product when purchased new and unused to be free from defects in materials and workmanship for a period of five years from date of purchase from Invacare or a dealer, with a copy of the seller's invoice required for coverage under this warranty. If within such warranty periods any such product shall be proven to be defective, such product shall be repaired or replaced, at Invacare's option. This warranty does not include any labor or shipping charges incurred in replacement part installation or repair of any such product. Invacare's sole obligation and your exclusive remedy under this warranty shall be limited to such repair and/or replacement. For warranty service, please contact the dealer from whom you purchased your Invacare product. In the event you do not receive satisfactory warranty service, please write directly to Invacare at the address on the back cover, provide dealer's name, address, and the date of purchase, indicate nature of the defect and, if the product is serialized, indicate the serial number. Do not return products to our factory without our prior consent.

LIMITATIONS AND EXCLUSIONS: THE FOREGOING WARRANTY SHALL NOT APPLY TO SERIAL NUMBERED PRODUCTS IF THE SERIAL NUMBER HAS BEEN REMOVED OR DEFACED, PRODUCTS SUBJECTED TO NEGLIGENCE, ACCIDENT, IMPROPER OPERATION, MAINTENANCE OR STORAGE, PRODUCTS MODIFIED WITHOUT INVACARE'S EXPRESS WRITTEN CONSENT (INCLUDING, BUT NOT LIMITED TO, MODIFICATION THROUGH THE USE OF UNAUTHORIZED PARTS OR ATTACHMENTS; PRODUCTS DAMAGED BY REASON OF REPAIRS MADE TO ANY COMPONENT WITHOUT THE SPECIFIC CONSENT OF INVACARE, OR TO A PRODUCT DAMAGED BY CIRCUMSTANCES BEYOND INVACARE'S CONTROL, AND SUCH EVALUATION WILL BE SOLELY DETERMINED BY INVACARE. THE WARRANTY SHALL NOT APPLY TO NORMAL WEAR AND TEAR OR FAILURE TO ADHERE TO THE PRODUCT INSTRUCTIONS.

THE FOREGOING EXPRESS WARRANTY IS EXCLUSIVE AND IN LIEU OF ANY OTHER WARRANTIES WHATSOEVER, WHETHER EXPRESS OR IMPLIED, INCLUDING THE IMPLIED WARRANTIES OF MERCHANTABILITY AND FITNESS FOR A PARTICULAR PURPOSE, AND THE SOLE REMEDY FOR VIOLATIONS OF ANY WARRANTY WHATSOEVER, SHALL BE LIMITED TO REPAIR OR REPLACEMENT OF THE DEFECTIVE PRODUCT PURSUANT TO THE TERMS CONTAINED HEREIN. THE APPLICATION OF ANY IMPLIED WARRANTY WHATSOEVER SHALL NOT EXTEND BEYOND THE DURATION OF THE EXPRESS WARRANTY PROVIDED HEREIN. INVACARE SHALL NOT BE LIABLE FOR ANY CONSEQUENTIAL OR INCIDENTAL DAMAGES WHATSOEVER.

SOME STATES DO NOT ALLOW THE EXCLUSION OR LIMITATION OF INCIDENTAL OR CONSEQUENTIAL DAMAGE, OR LIMITATION OF HOW LONG AN IMPLIED WARRANTY LASTS, SO THE ABOVE EXCLUSION AND LIMITATION MAY NOT BE APPLICABLE.

THIS WARRANTY SHALL BE EXTENDED TO COMPLY WITH STATE/PROVINCIAL LAWS AND REQUIREMENTS.

Invacare Corporation www.invacare.com



Yes, you can.

USA
One Invacare Way
Elyria, Ohio USA
44036-2125
800-333-6900

Canada
570 Matheson Blvd E Unit 8
Mississauga Ontario
L4Z 4G4 Canada
800-668-5324

All rights reserved. Trademarks are identified by the symbols [™] and [®]. All trademarks are owned by or licensed to Invacare Corporation unless otherwise noted.

© 2007 Invacare Corporation

Part No 1123842

Rev G - 08/07